

TCS 1
TYPICAL CROSS SECTION FOR 2 LANE IN EXISTING SECTION

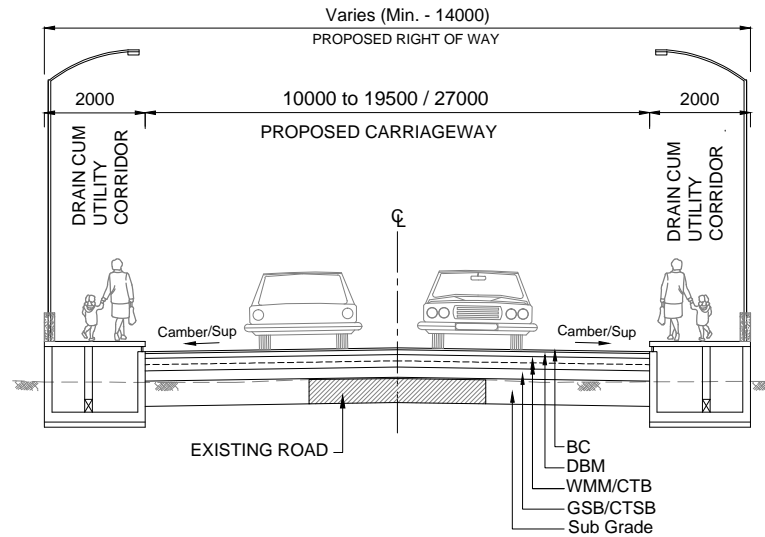





Note :
 All Dimensions are in mm unless otherwise specified.

 PUBLIC WORKS DEPARTMENT GOVERNMENT OF MANIPUR	Project Title:- Consultancy Services for Feasibility Study and Preparation of Detailed Project Report for Proposed Construction of Imphal Ring Road in the state of Manipur (Imphal Ring Road)	Scale:- Not to Scale	Drawing Name:- DETAILED PROJECT REPORT TYPICAL CROSS SECTION	Intercontinental Consultants & Technocrats Pvt Ltd, A-8, Green Park, New Delhi - 110016 Ph : 4086-3000, Fax : 2685-5252	R0 Revisions	September, 2022 Date	Initial Drawings Description	Checked by
					Revisions			
					DRAWING No:- PWD/IMPHAL RING ROAD/TCS/ 01/R0 FILE NAME:-			



TCS 1A
TYPICAL CROSS SECTION FOR 2 ~ 4 LANE MERGING SECTION IN EXISTING SECTION





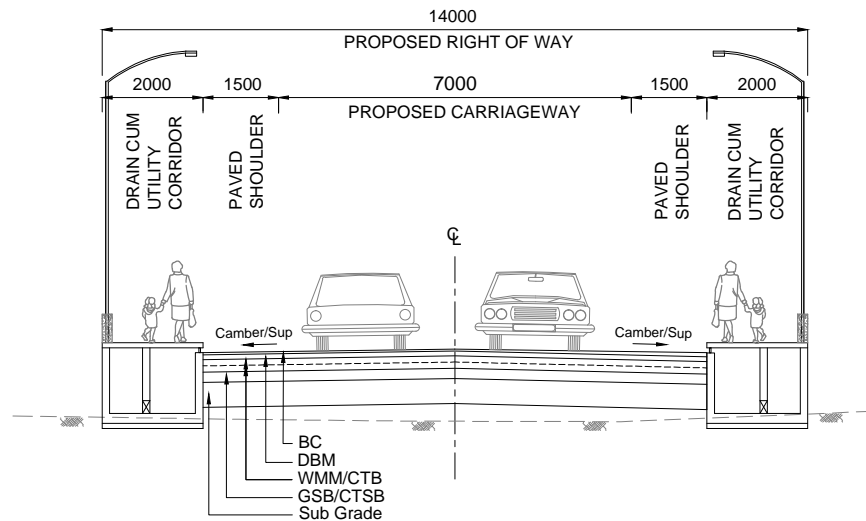

Note :
 All Dimensions are in mm unless otherwise specified.

 PUBLIC WORKS DEPARTMENT GOVERNMENT OF MANIPUR	Project Title:- Consultancy Services for Feasibility Study and Preparation of Detailed Project Report for Proposed Construction of Imphal Ring Road in the state of Manipur (Imphal Ring Road)	Scale:- Not to Scale	Drawing Name:- DETAILED PROJECT REPORT TYPICAL CROSS SECTION	 Intercontinental Consultants & Technocrats Pvt Ltd, A-8, Green Park, New Delhi - 110016 Ph : 4086-3000, Fax : 2685-5252	R0	September, 2022	Initial Drawings	
					Revisions	Date	Description	Checked by
					Revisions			
Prepared by:  Hilsitt Designed by:  B.K Swain Checked by:  Ananta Prabhakar Approved by:  Dinesh Kumar					DRAWING No:- PWD/IMPHAL RING ROAD/TCS/ 02 /R0 FILE NAME:-			



TCS - 2
TYPICAL CROSS SECTION FOR 2 LANE IN GREEN FIELD SECTION





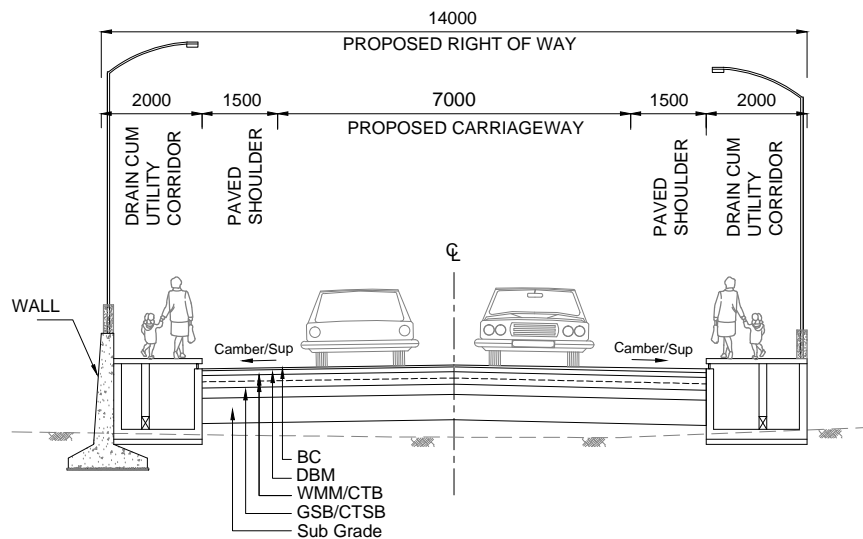

Note :
 All Dimensions are in mm unless otherwise specified.

 PUBLIC WORKS DEPARTMENT GOVERNMENT OF MANIPUR	Project Title:- Consultancy Services for Feasibility Study and Preparation of Detailed Project Report for Proposed Construction of Imphal Ring Road in the state of Manipur (Imphal Ring Road)	Scale:- Not to Scale	Drawing Name:- DETAILED PROJECT REPORT TYPICAL CROSS SECTION	 Intercontinental Consultants & Technocrats Pvt Ltd, A-8, Green Park, New Delhi - 110016 Ph : 4086-3000, Fax : 2685-5252	R0	September, 2022	Initial Drawings	
					Revisions	Date	Description	Checked by
					Revisions			
Prepared by:  Hilsitt Designed by:  B.K Swain Checked by:  Anand Prabhakar Approved by:  Dinesh Kumar					DRAWING No:- PWD/IMPHAL RING ROAD/TCS/ 03 /R0 FILE NAME:-			



TCS - 2A
TYPICAL CROSS SECTION FOR 2 LANE IN GREEN FIELD SECTION WITH RETAINING WALL - LHS





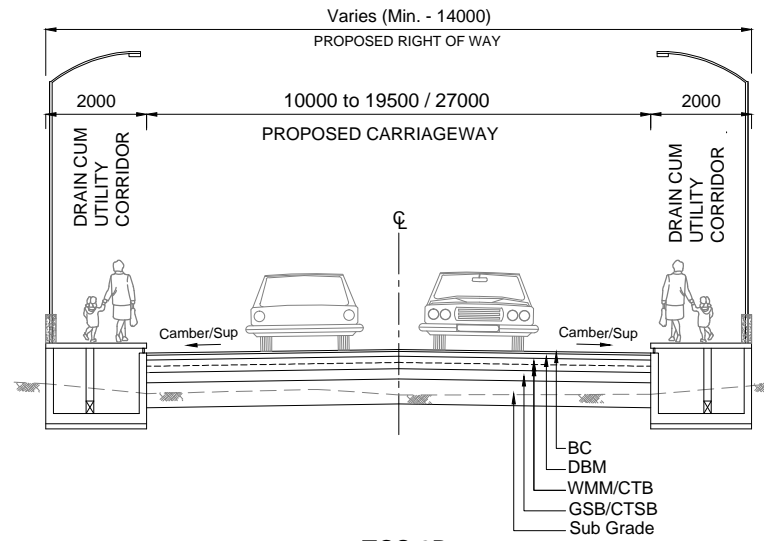

Note :
 All Dimensions are in mm unless otherwise specified.

 PUBLIC WORKS DEPARTMENT GOVERNMENT OF MANIPUR	Project Title:- Consultancy Services for Feasibility Study and Preparation of Detailed Project Report for Proposed Construction of Imphal Ring Road in the state of Manipur (Imphal Ring Road)	Scale:- Not to Scale	Drawing Name:- DETAILED PROJECT REPORT TYPICAL CROSS SECTION	 Intercontinental Consultants & Technocrats Pvt Ltd, A-8, Green Park, New Delhi - 110016 Ph : 4086-3000, Fax : 2685-5252	R0	September, 2022	Initial Drawings	
					Revisions	Date	Description	Checked by
					Revisions			
Prepared by:  Hilsitt Designed by:  B.K Swain Checked by:  Anand Prabhakar Approved by:  Dinesh Kumar					DRAWING No:- PWD/IMPHAL RING ROAD/TCS/ 04/R0 FILE NAME:-			



TCS 2B
TYPICAL CROSS SECTION FOR 2 ~ 4 LANE MERGING SECTION IN GREEN FIELD





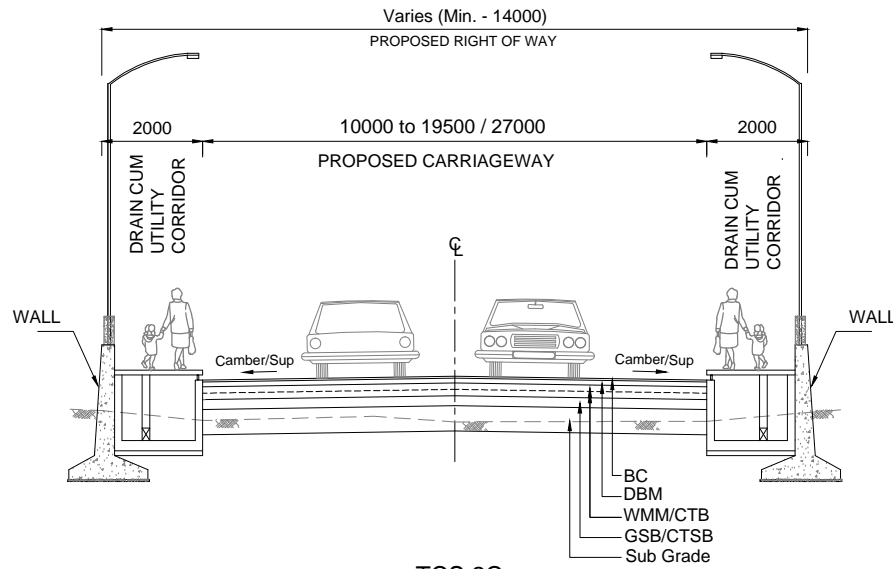

Note :
 All Dimensions are in mm unless otherwise specified.

 PUBLIC WORKS DEPARTMENT GOVERNMENT OF MANIPUR	Project Title:- Consultancy Services for Feasibility Study and Preparation of Detailed Project Report for Proposed Construction of Imphal Ring Road in the state of Manipur (Imphal Ring Road)	Scale:- Not to Scale	Drawing Name:- DETAILED PROJECT REPORT TYPICAL CROSS SECTION	 Intercontinental Consultants & Technocrats Pvt Ltd, A-8, Green Park, New Delhi - 110016 Ph : 4086-3000, Fax : 2685-5252	R0	September, 2022	Initial Drawings	
					Revisions	Date	Description	Checked by
					Revisions			
Prepared by:  Hilsitt Designed by:  B.K. Swain Checked by:  Ananta Prabhakar Approved by:  Dinesh Kumar					DRAWING No:- PWD/IMPHAL RING ROAD/TCS/ 05/R0 FILE NAME:-			



TCS 2C
TYPICAL CROSS SECTION FOR 2 ~ 4 LANE MERGING SECTION IN GREEN FIELD WITH BOTHSIDE RETAINING WALL





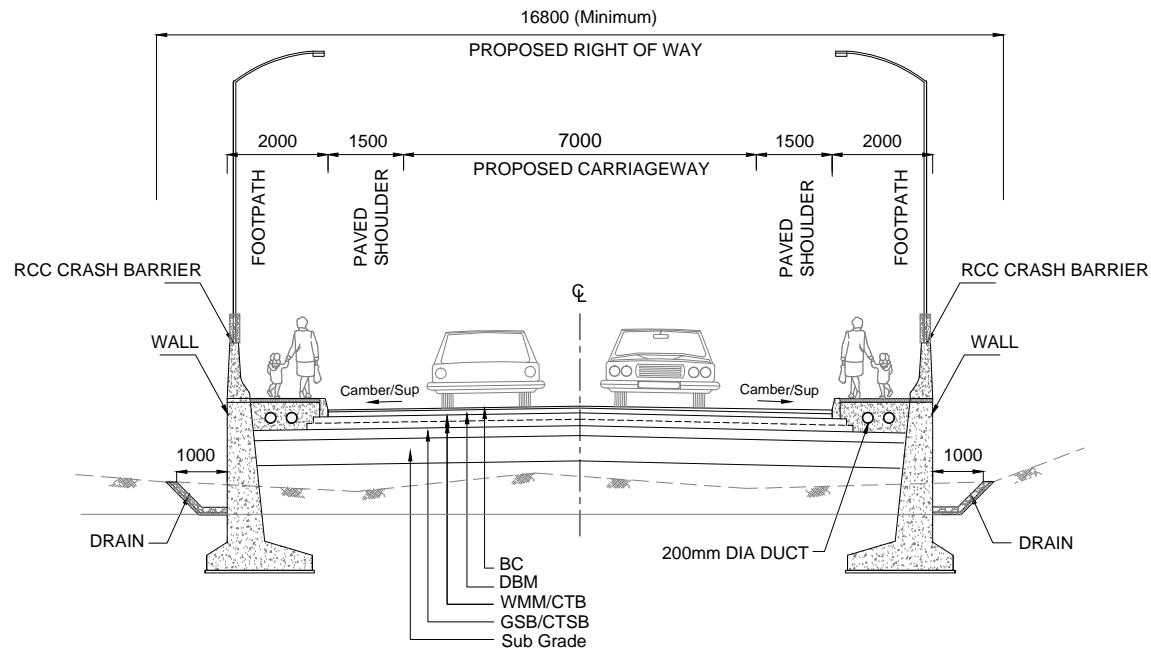

Note :
 All Dimensions are in mm unless otherwise specified.

 PUBLIC WORKS DEPARTMENT GOVERNMENT OF MANIPUR	Project Title:- Consultancy Services for Feasibility Study and Preparation of Detailed Project Report for Proposed Construction of Imphal Ring Road in the state of Manipur (Imphal Ring Road)	Scale:- Not to Scale	Drawing Name:- DETAILED PROJECT REPORT TYPICAL CROSS SECTION	 Intercontinental Consultants & Technocrats Pvt Ltd, A-8, Green Park, New Delhi - 110016 Ph : 4086-3000, Fax : 2685-5252	R0	September, 2022	Initial Drawings	
					Revisions	Date	Description	Checked by
					Revisions			
Prepared by:  Hilsitt Designed by:  B.K Swain Checked by:  Ananta Prabhakar Approved by:  Dinesh Kumar					DRAWING No:- PWD/IMPHAL RING ROAD/TCS/ 06 /R0 FILE NAME:-			



TCS 3
TYPICAL CROSS SECTION FOR 2 LANE IN GREEN FIELD (HIGH EMBANKMENT)

Note :
 All Dimensions are in mm unless otherwise specified.

 PUBLIC WORKS DEPARTMENT GOVERNMENT OF MANIPUR	Project Title:- Consultancy Services for Feasibility Study and Preparation of Detailed Project Report for Proposed Construction of Imphal Ring Road in the state of Manipur (Imphal Ring Road)	Scale:- Not to Scale	Drawing Name:- DETAILED PROJECT REPORT TYPICAL CROSS SECTION	 Intercontinental Consultants & Technocrats Pvt Ltd, A-8, Green Park, New Delhi - 110016 Ph : 4086-3000, Fax : 2685-5252	R0	September, 2022	Initial Drawings	
					Revisions	Date	Description	Checked by
					Revisions			
Prepared by:  Hilsitt Designed by:  B.K Swain Checked by:  Anand Prabhakar Approved by:  Dinesh Kumar					DRAWING No:- PWD/IMPHAL RING ROAD/TCS/ 07 /R0 FILE NAME:-			

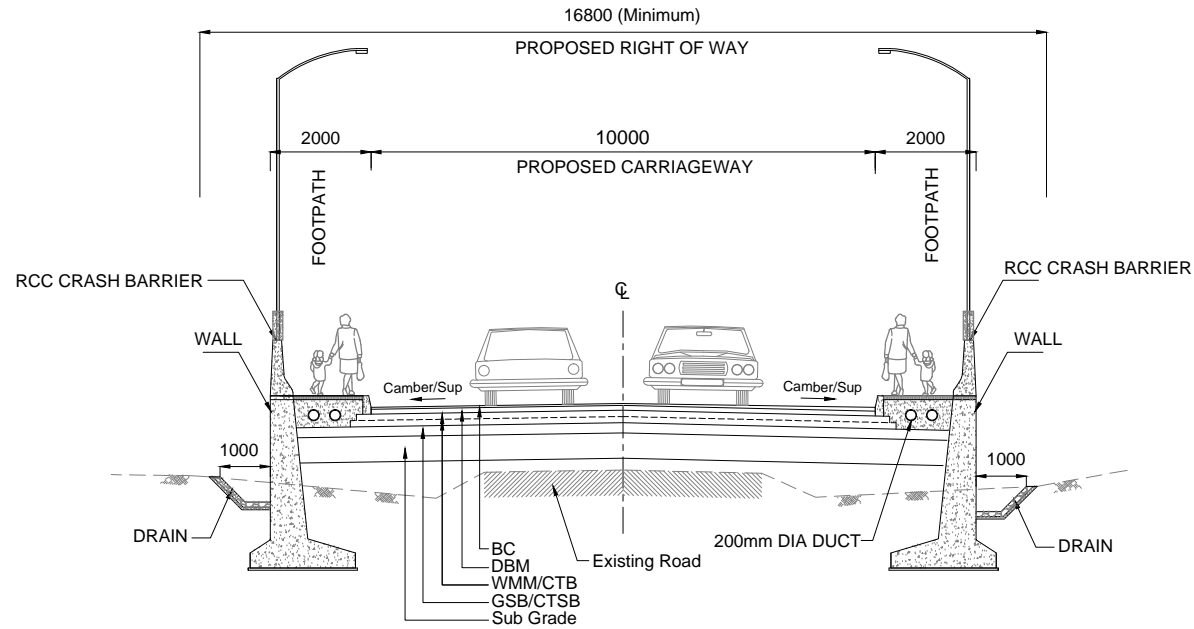

TCS 3A
TYPICAL CROSS SECTION FOR 2 LANE IN EXISTING WITH RETAINING WALL ON MERGING SECTION

Note :
 All Dimensions are in mm unless otherwise specified.

 PUBLIC WORKS DEPARTMENT GOVERNMENT OF MANIPUR	Project Title:- Consultancy Services for Feasibility Study and Preparation of Detailed Project Report for Proposed Construction of Imphal Ring Road in the state of Manipur (Imphal Ring Road)	Scale:- Not to Scale	Drawing Name:- DETAILED PROJECT REPORT TYPICAL CROSS SECTION	Intercontinental Consultants & Technocrats Pvt Ltd, A-8, Green Park, New Delhi - 110016 Ph : 4086-3000, Fax : 2685-5252	<table border="1" style="width: 100%; border-collapse: collapse;"> <tr> <td style="width: 20%;">R0</td> <td style="width: 20%;">September, 2022</td> <td style="width: 60%;">Initial Drawings</td> </tr> <tr> <td>Revisions</td> <td>Date</td> <td>Description</td> </tr> <tr> <td colspan="3" style="text-align: center;">Revisions</td> </tr> </table>	R0	September, 2022	Initial Drawings	Revisions	Date	Description	Revisions		
	R0	September, 2022	Initial Drawings											
	Revisions	Date	Description											
Revisions														
<table border="1" style="width: 100%; border-collapse: collapse;"> <tr> <td style="width: 25%; text-align: center;"> Hilsitt Prepared by </td> <td style="width: 25%; text-align: center;"> B.K Swain Designed by </td> <td style="width: 25%; text-align: center;"> Anand Prabhakar Checked by </td> <td style="width: 25%; text-align: center;"> Dinesh Kumar Approved by </td> </tr> </table>				 Hilsitt Prepared by	 B.K Swain Designed by	 Anand Prabhakar Checked by	 Dinesh Kumar Approved by	DRAWING No:- PWD/IMPHAL RING ROAD/TCS/ 08 /R0 FILE NAME:-						
 Hilsitt Prepared by	 B.K Swain Designed by	 Anand Prabhakar Checked by	 Dinesh Kumar Approved by											
Prepared by: Hilsitt Designed by: B.K Swain Checked by: Anand Prabhakar Approved by: Dinesh Kumar														

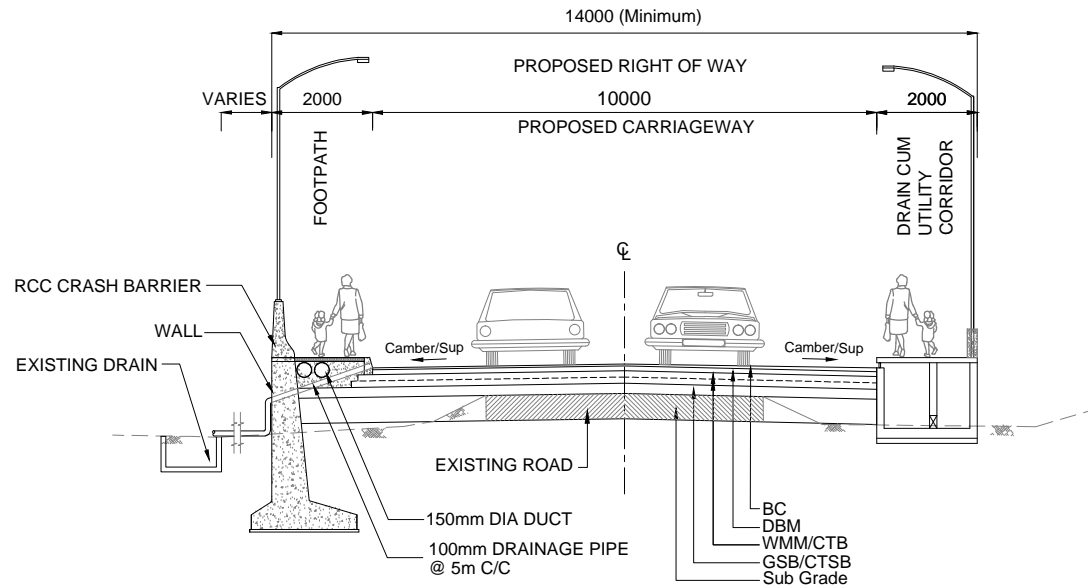

TCS 3B
TYPICAL CROSS SECTION FOR 2 LANE IN EXISTING DRAIN (LHS) SECTION

Note :
 All Dimensions are in mm unless otherwise specified.

 PUBLIC WORKS DEPARTMENT GOVERNMENT OF MANIPUR	Project Title:- Consultancy Services for Feasibility Study and Preparation of Detailed Project Report for Proposed Construction of Imphal Ring Road in the state of Manipur (Imphal Ring Road)	Scale:- Not to Scale	Drawing Name:- DETAILED PROJECT REPORT TYPICAL CROSS SECTION	Intercontinental Consultants & Technocrats Pvt Ltd, A-8, Green Park, New Delhi - 110016 Ph : 4086-3000, Fax : 2685-5252	R0 Revisions	September, 2022 Date	Initial Drawings Description	Checked by
					Revisions			
					DRAWING No:- PWD/IMPHAL RING ROAD/TCS/ 09 /R0 FILE NAME:-			

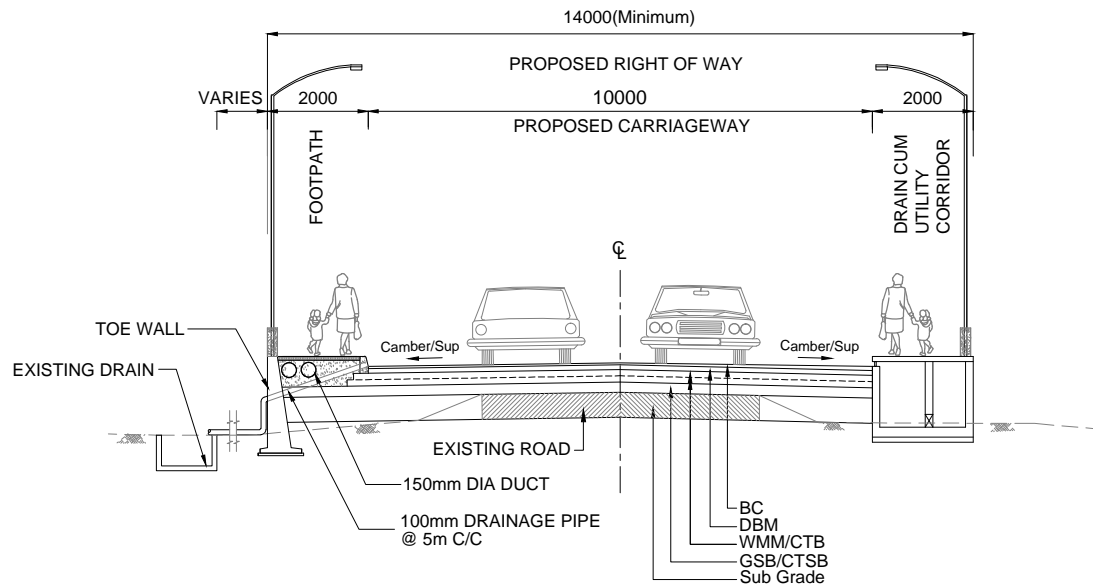

TCS 3C
TYPICAL CROSS SECTION FOR 2 LANE IN EXISTING DRAIN (LHS) WITH TOE WALL

Note :
 All Dimensions are in mm unless otherwise specified.

 PUBLIC WORKS DEPARTMENT GOVERNMENT OF MANIPUR	Project Title:- Consultancy Services for Feasibility Study and Preparation of Detailed Project Report for Proposed Construction of Imphal Ring Road in the state of Manipur (Imphal Ring Road)	Scale:- Not to Scale	Drawing Name:- DETAILED PROJECT REPORT TYPICAL CROSS SECTION	Intercontinental Consultants & Technocrats Pvt Ltd, A-8, Green Park, New Delhi - 110016 Ph : 4086-3000, Fax : 2685-5252	R0 Revisions	September, 2022 Date	Initial Drawings Description	Checked by
					Revisions			
					DRAWING No:- PWD/IMPHAL RING ROAD/TCS/ 10 /R0 FILE NAME:-			

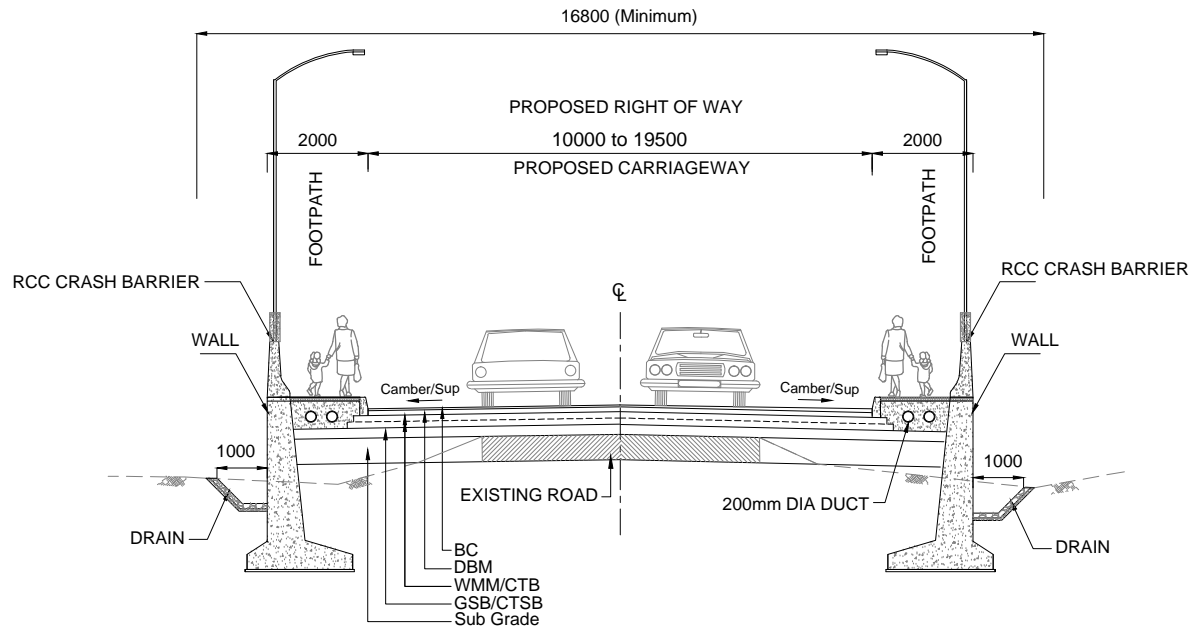

TCS 3D
TYPICAL CROSS SECTION FOR 2 LANE IN EXISTING ON HIGH EMBANKMENT ON MERGING SECTION

Note :
 All Dimensions are in mm unless otherwise specified.

 PUBLIC WORKS DEPARTMENT GOVERNMENT OF MANIPUR	Project Title:- Consultancy Services for Feasibility Study and Preparation of Detailed Project Report for Proposed Construction of Imphal Ring Road in the state of Manipur (Imphal Ring Road)	Scale:- Not to Scale	Drawing Name:- DETAILED PROJECT REPORT TYPICAL CROSS SECTION	Intercontinental Consultants & Technocrats Pvt Ltd, A-8, Green Park, New Delhi - 110016 Ph : 4086-3000, Fax : 2685-5252	<table border="1" style="width: 100%; border-collapse: collapse;"> <tr> <td style="width: 20%;">R0</td> <td style="width: 20%;">September, 2022</td> <td style="width: 60%;">Initial Drawings</td> </tr> <tr> <td>Revisions</td> <td>Date</td> <td>Description</td> </tr> <tr> <td colspan="3" style="text-align: center;">Revisions</td> </tr> </table>	R0	September, 2022	Initial Drawings	Revisions	Date	Description	Revisions		
	R0	September, 2022	Initial Drawings											
	Revisions	Date	Description											
Revisions														
				DRAWING No:- PWD/IMPHAL RING ROAD/TCS/ 11/R0										
				FILE NAME:-										

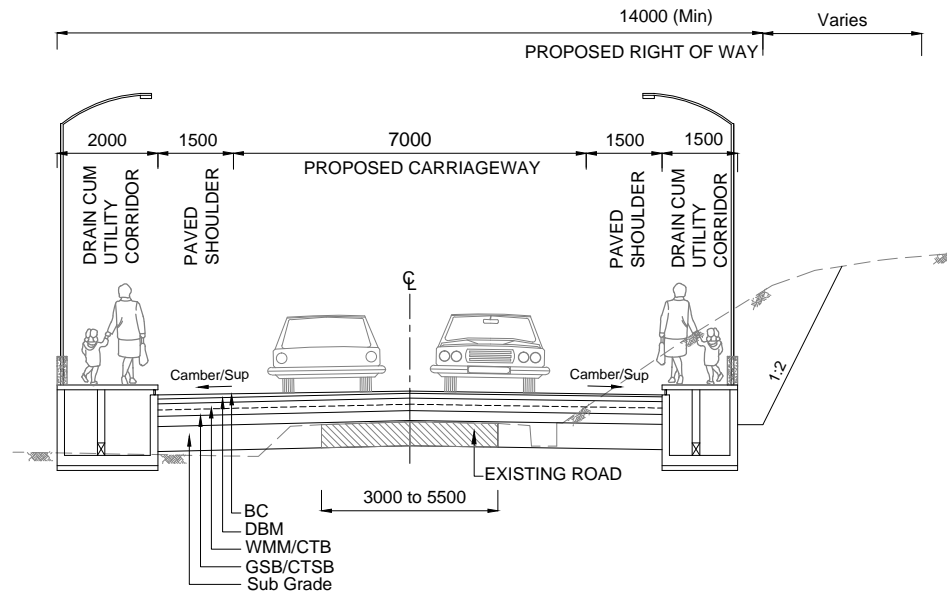

TCS 4
TYPICAL CROSS SECTION FOR 2 LANE WITH HALF CUT IN EXISTING SECTION (RHS)

Note :
 All Dimensions are in mm unless otherwise specified.

 PUBLIC WORKS DEPARTMENT GOVERNMENT OF MANIPUR	Project Title:- Consultancy Services for Feasibility Study and Preparation of Detailed Project Report for Proposed Construction of Imphal Ring Road in the state of Manipur (Imphal Ring Road)	Scale:- Not to Scale	Drawing Name:- DETAILED PROJECT REPORT TYPICAL CROSS SECTION	Intercontinental Consultants & Technocrats Pvt Ltd, A-8, Green Park, New Delhi - 110016 Ph : 4086-3000, Fax : 2685-5252	<table border="1" style="width: 100%; border-collapse: collapse;"> <tr> <td>R0</td> <td>September, 2022</td> <td>Initial Drawings</td> </tr> <tr> <td>Revisions</td> <td>Date</td> <td>Description</td> </tr> <tr> <td colspan="3" style="text-align: center;">Revisions</td> </tr> </table>	R0	September, 2022	Initial Drawings	Revisions	Date	Description	Revisions		
	R0	September, 2022	Initial Drawings											
	Revisions	Date	Description											
Revisions														
<table border="1" style="width: 100%; border-collapse: collapse;"> <tr> <td style="width: 25%;"></td> <td style="width: 25%;"></td> <td style="width: 25%;"></td> <td style="width: 25%;"></td> </tr> <tr> <td>Prepared by</td> <td>Designed by</td> <td>Checked by</td> <td>Approved by</td> </tr> </table>								Prepared by	Designed by	Checked by	Approved by	DRAWING No:- PWD/IMPHAL RING ROAD/TCS/ 12 /R0 FILE NAME:-		
Prepared by	Designed by	Checked by	Approved by											
Prepared by: Hilsitt, Designed by: B.K Swain, Checked by: Anand Prabhakar, Approved by: Dinesh Kumar														

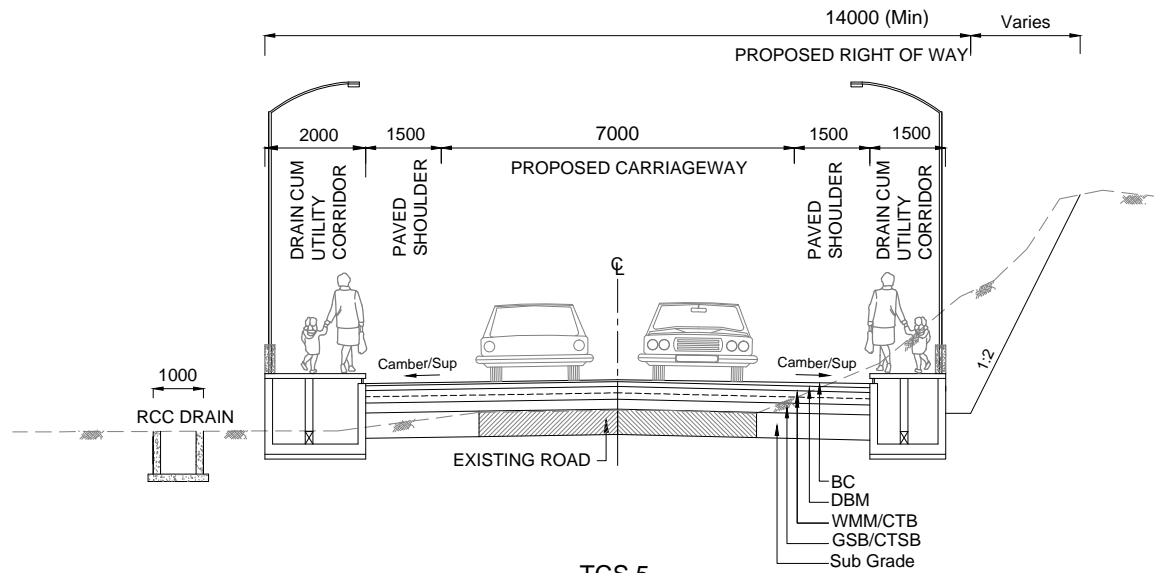



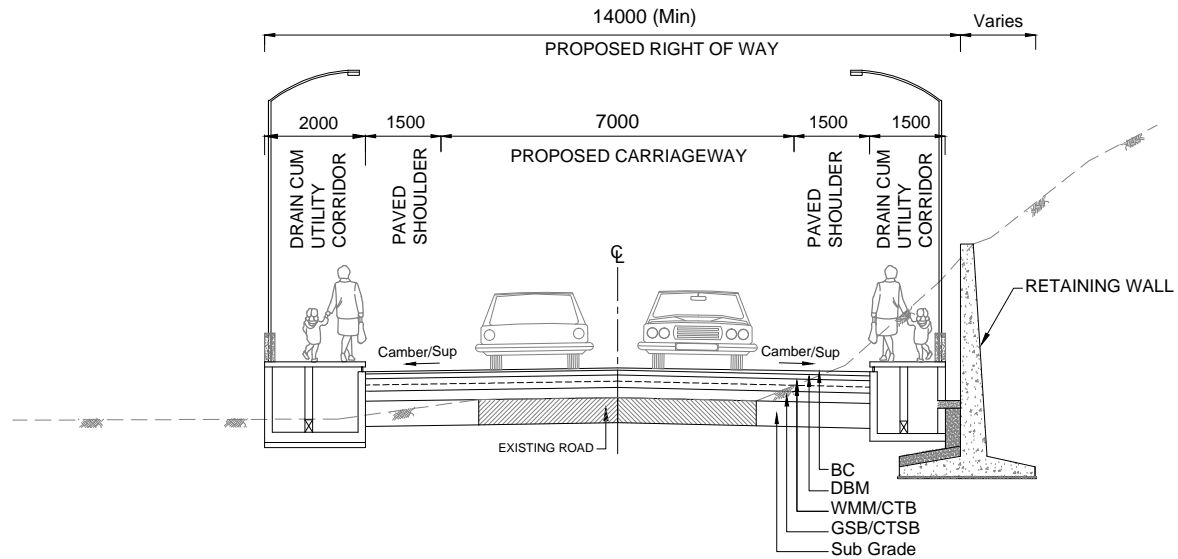

TCS 5
TYPICAL CROSS SECTION FOR 2 LANE WITH HALF CUT IN EXISTING - RHS (BUILT UP SECTION)

Note :
 All Dimensions are in mm unless otherwise specified.



TCS 5A
TYPICAL CROSS SECTION FOR 2 LANE IN HALF CUT IN EXISTING WITH RETAINING WALL - RHS

Note :
 All Dimensions are in mm unless otherwise specified.

 PUBLIC WORKS DEPARTMENT GOVERNMENT OF MANIPUR	Project Title:- Consultancy Services for Feasibility Study and Preparation of Detailed Project Report for Proposed Construction of Imphal Ring Road in the state of Manipur (Imphal Ring Road)	Scale:- Not to Scale	Drawing Name:- DETAILED PROJECT REPORT TYPICAL CROSS SECTION	 Intercontinental Consultants & Technocrats Pvt Ltd, A-8, Green Park, New Delhi - 110016 Ph : 4086-3000, Fax : 2685-5252	R0 Revisions	September, 2022 Date	Initial Drawings Description	Checked by				
					Revisions				DRAWING No:- PWD/IMPHAL RING ROAD/TCS/ 14 /R0			
					Prepared by 				Designed by 		Checked by 	

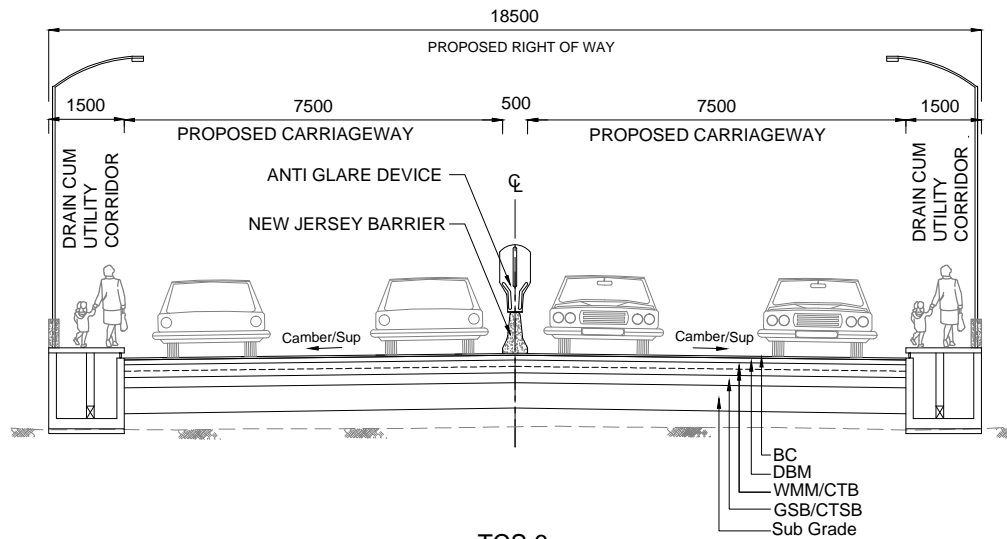

TCS 6
TYPICAL CROSS SECTION FOR 4 LANE DIVIDED CARRIAGEWAY
WITHOUT SERVICE ROAD (GREEN FIELD SECTION)

Note :

- (1) All Dimensions are in mm unless otherwise specified.
- (2) For details of New Jersey Barrier and Anti Glare Device refer TCS 16.

 PUBLIC WORKS DEPARTMENT GOVERNMENT OF MANIPUR	Project Title:- Consultancy Services for Feasibility Study and Preparation of Detailed Project Report for Proposed Construction of Imphal Ring Road in the state of Manipur (Imphal Ring Road)	Scale:- Not to Scale	Drawing Name:- DETAILED PROJECT REPORT TYPICAL CROSS SECTION	Intercontinental Consultants & Technocrats Pvt Ltd, A-8, Green Park, New Delhi - 110016 Ph : 4086-3000, Fax : 2685-5252	R0 September, 2022	Initial Drawings	Checked by
					Revisions Date	Description	Revisions
					Prepared by Hilsitt	Designed by B.K Swain	Checked by Anand Prabhakar
					DRAWING No:- PWD/IMPHAL RING ROAD/TCS/ 15 /R0		
					FILE NAME:-		

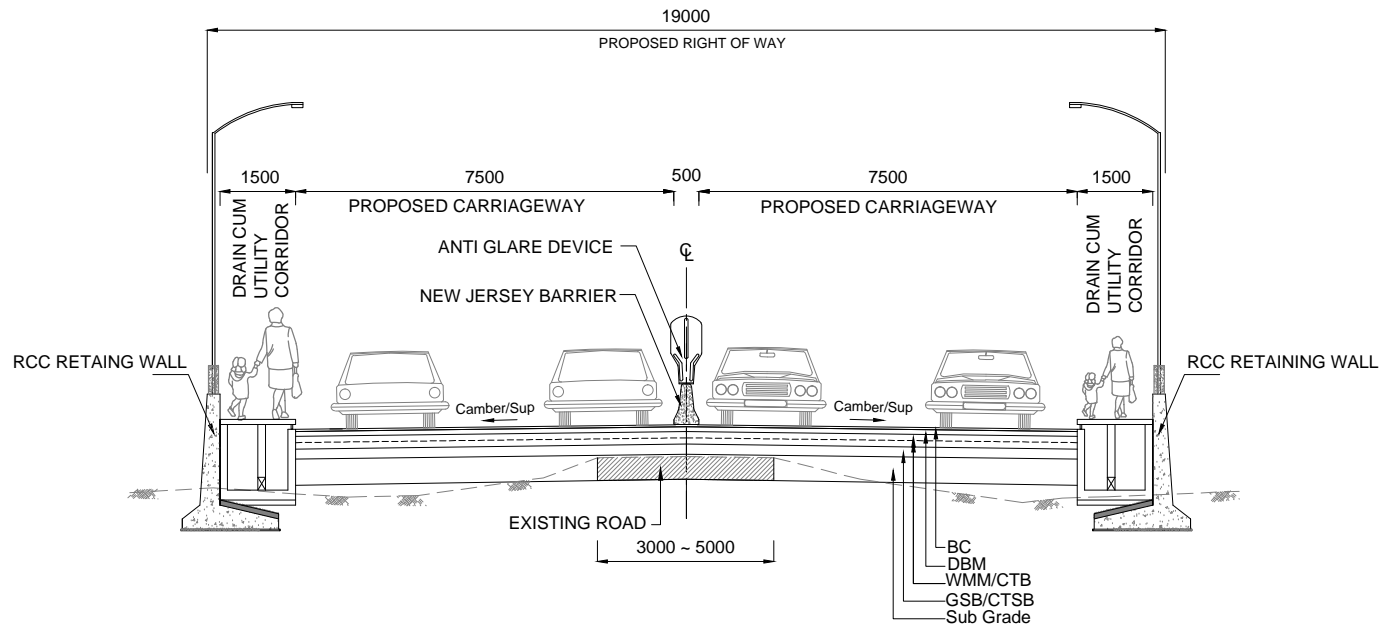

TCS 7
TYPICAL CROSS SECTION FOR 4 LANE DIVIDED CARRIAGEWAY
WITHOUT SERVICE ROAD ON HIGH EMBANKMENT SECTION

Note :

- (1) All Dimensions are in mm unless otherwise specified.
- (2) For details of New Jersey Barrier and Anti Glare Device refer TCS 16.

 PUBLIC WORKS DEPARTMENT GOVERNMENT OF MANIPUR	Project Title:- Consultancy Services for Feasibility Study and Preparation of Detailed Project Report for Proposed Construction of Imphal Ring Road in the state of Manipur (Imphal Ring Road)	Scale:- Not to Scale	Drawing Name:- DETAILED PROJECT REPORT TYPICAL CROSS SECTION	Intercontinental Consultants & Technocrats Pvt Ltd, A-8, Green Park, New Delhi - 110016 Ph : 4086-3000, Fax : 2685-5252	R0 September, 2022	Initial Drawings	Checked by					
					Revisions	Date	Description	Revisions				
					<table style="width: 100%; border-collapse: collapse;"> <tr> <td style="font-size: x-small; text-align: center;"> Prepared by </td> <td style="font-size: x-small; text-align: center;"> Designed by </td> <td style="font-size: x-small; text-align: center;"> Checked by </td> <td style="font-size: x-small; text-align: center;"> Approved by </td> </tr> </table>	 Prepared by	 Designed by	 Checked by	 Approved by	DRAWING No:- PWD/IMPHAL RING ROAD/TCS/ 16 /R0		
 Prepared by	 Designed by	 Checked by	 Approved by									

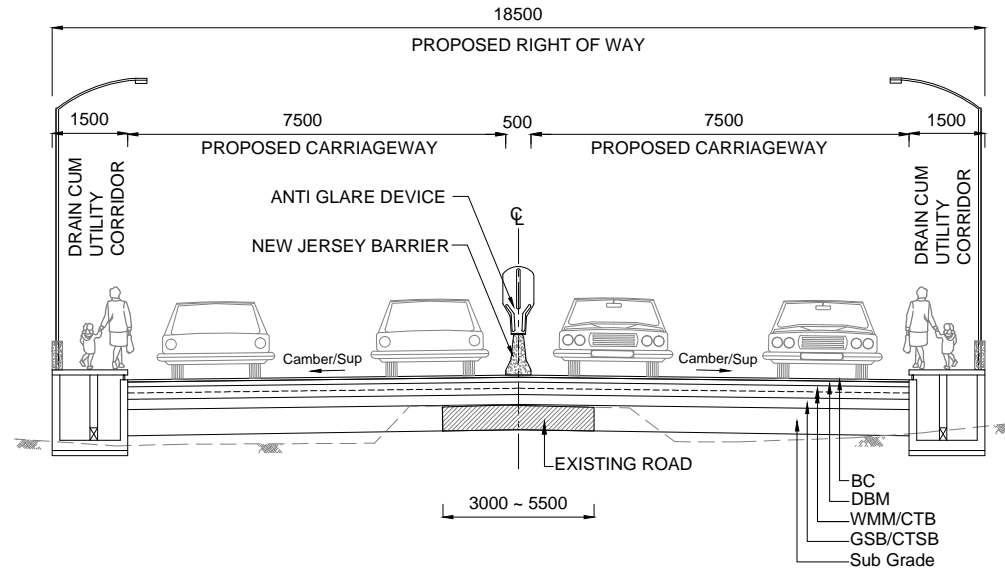

TCS 8
TYPICAL CROSS SECTION FOR 4 LANE DIVIDED CARRIAGEWAY
WITHOUT SERVICE ROAD (EXITING ROAD SECTION)

Note :

- (1) All Dimensions are in mm unless otherwise specified.
- (2) For details of New Jersey Barrier and Anti Glare Device refer TCS 16.

 PUBLIC WORKS DEPARTMENT GOVERNMENT OF MANIPUR	Project Title:-	Scale:-	Drawing Name:-	Intercontinental Consultants & Technocrats Pvt Ltd, A-8, Green Park, New Delhi - 110016 Ph : 4086-3000, Fax : 2685-5252	R0	September, 2022	Initial Drawings	
	Consultancy Services for Feasibility Study and Preparation of Detailed Project Report for Proposed Construction of Imphal Ring Road in the state of Manipur (Imphal Ring Road)	Not to Scale	DETAILED PROJECT REPORT TYPICAL CROSS SECTION		Revisions	Date	Description	Checked by
					Prepared by	Designed by	Checked by	Approved by
							DRAWING No:- PWD/IMPHAL RING ROAD/TCS/ 17 /R0	FILE NAME:-

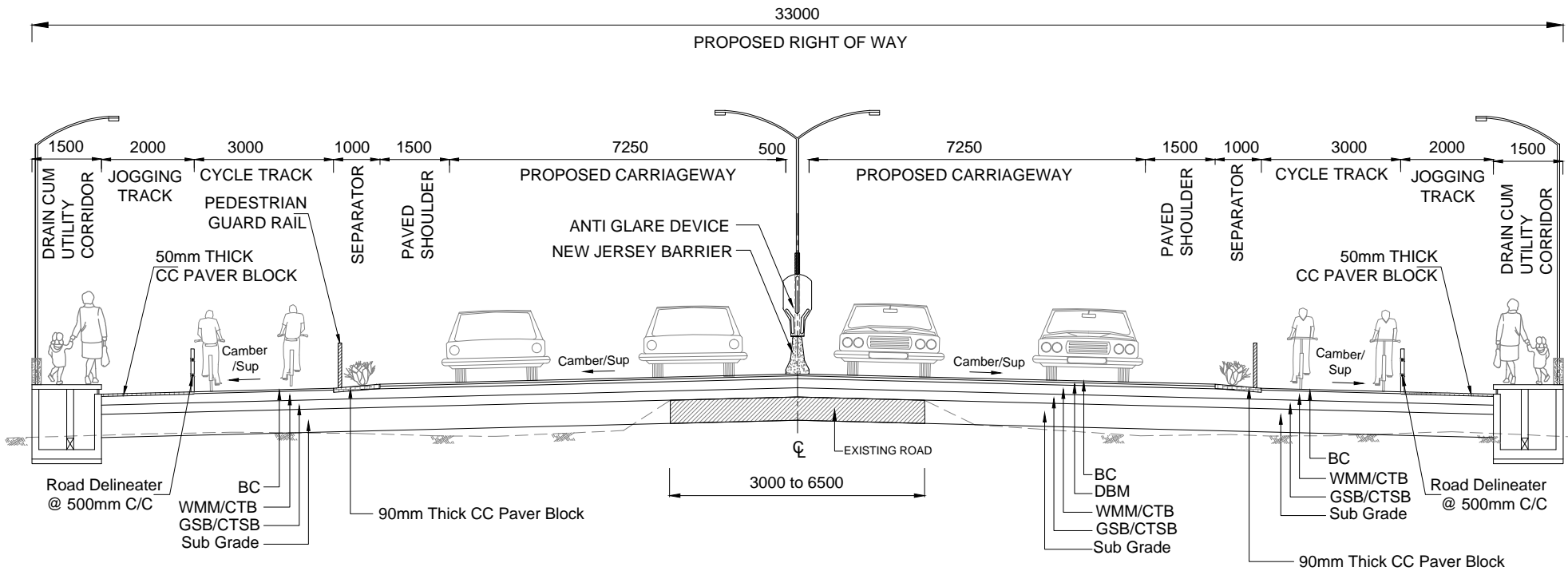

TCS 9
TYPICAL CROSS SECTION FOR 4 LANE DIVIDED CARRIAGEWAY WITH BOTH SIDE CYCLE TRACK





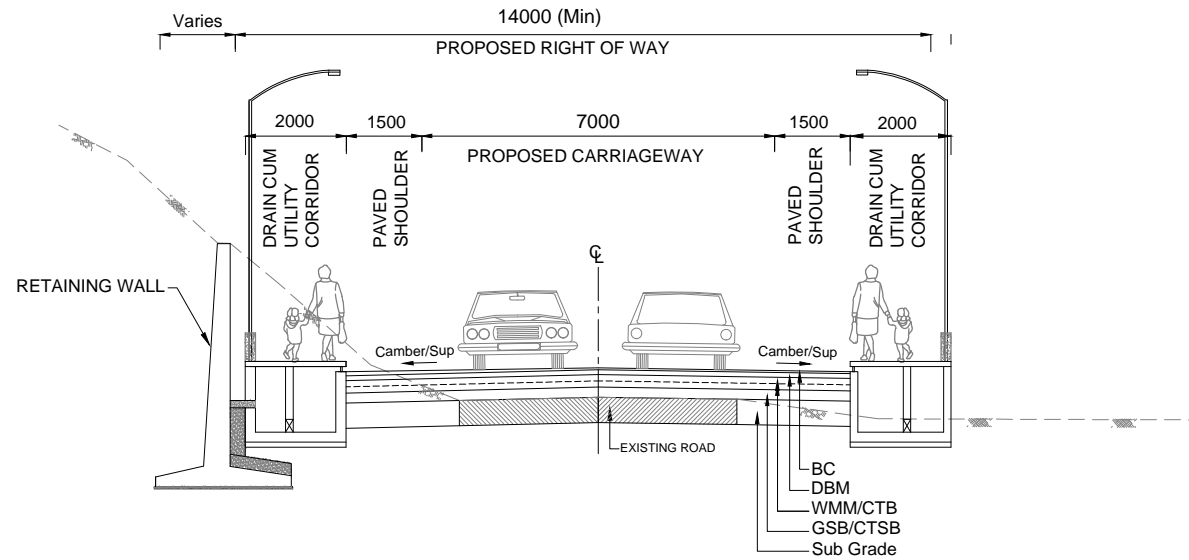

- Note :
- (1) All Dimensions are in mm unless otherwise specified.
 - (2) For details of New Jersey Barrier and Anti Glare Device refer TCS 16.

 PUBLIC WORKS DEPARTMENT GOVERNMENT OF MANIPUR	Project Title:- Consultancy Services for Feasibility Study and Preparation of Detailed Project Report for Proposed Construction of Imphal Ring Road in the state of Manipur (Imphal Ring Road)	Scale:- Not to Scale	Drawing Name:- DETAILED PROJECT REPORT TYPICAL CROSS SECTION	Intercontinental Consultants & Technocrats Pvt Ltd, A-8, Green Park, New Delhi - 110016 Ph : 4086-3000, Fax : 2685-5252	R0 Revisions	September, 2022 Date	Initial Drawings Description Revisions	Checked by
	DRAWING No:- PWD/IMPHAL RING ROAD/TCS/ 18 /R0				FILE NAME:-			
	Prepared by Hilsitt		Designed by B.K Swain		Checked by Anand Prabhakar		Approved by Dinesh Kumar	



TCS 10
TYPICAL CROSS SECTION FOR 2 LANE IN HALF CUT WITH RETAINING WALL - LHS

Note :
 All Dimensions are in mm unless otherwise specified.

 PUBLIC WORKS DEPARTMENT GOVERNMENT OF MANIPUR	Project Title:- Consultancy Services for Feasibility Study and Preparation of Detailed Project Report for Proposed Construction of Imphal Ring Road in the state of Manipur (Imphal Ring Road)	Scale:- Not to Scale	Drawing Name:- DETAILED PROJECT REPORT TYPICAL CROSS SECTION	 Intercontinental Consultants & Technocrats Pvt Ltd, A-8, Green Park, New Delhi - 110016 Ph : 4086-3000, Fax : 2685-5252	R0	September, 2022	Initial Drawings	
					Revisions	Date	Description	Checked by
					Revisions			
Prepared by:  Hilsitt Designed by:  B.K Swain Checked by:  Anand Prabhakar Approved by:  Dinesh Kumar					DRAWING No:- PWD/IMPHAL RING ROAD/TCS/ 19 /R0 FILE NAME:-			

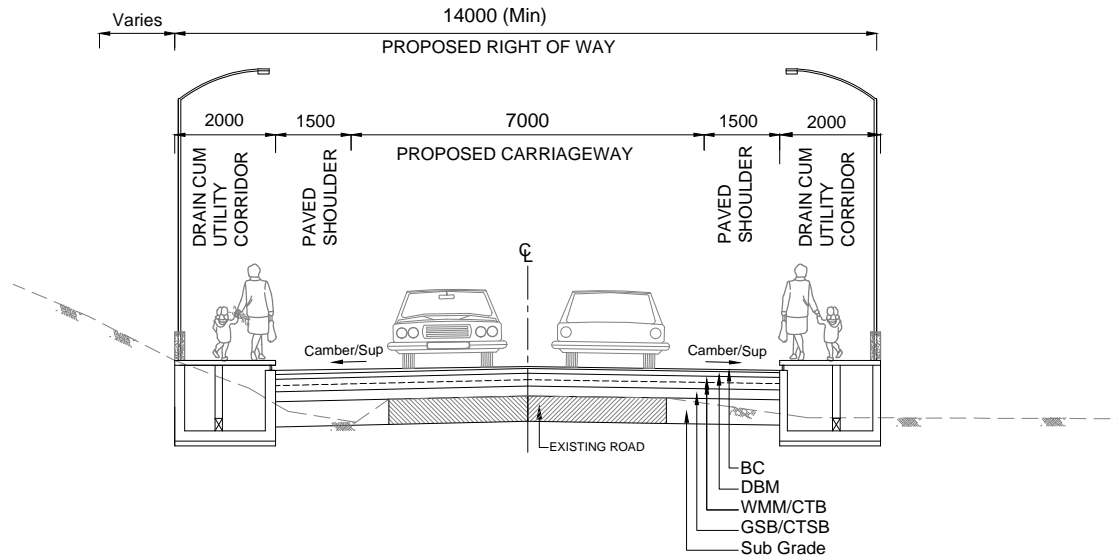

TCS 10A
TYPICAL CROSS SECTION FOR 2 LANE IN HALF CUT WITHOUT RETAINING WALL - LHS

Note :
 All Dimensions are in mm unless otherwise specified.

 PUBLIC WORKS DEPARTMENT GOVERNMENT OF MANIPUR	Project Title:- Consultancy Services for Feasibility Study and Preparation of Detailed Project Report for Proposed Construction of Imphal Ring Road in the state of Manipur (Imphal Ring Road)	Scale:- Not to Scale	Drawing Name:- DETAILED PROJECT REPORT TYPICAL CROSS SECTION		Intercontinental Consultants & Technocrats Pvt Ltd, A-8, Green Park, New Delhi - 110016 Ph : 4086-3000, Fax : 2685-5252	R0 Revisions	September, 2022 Date	Initial Drawings Description	Checked by			
					Revisions				DRAWING No:- PWD/IMPHAL RING ROAD/TCS/ 20/R0			
					Prepared by: Hilsitt Designed by: B.K Swain Checked by: Anand Prabhakar Approved by: Dinesh Kumar				FILE NAME:-			

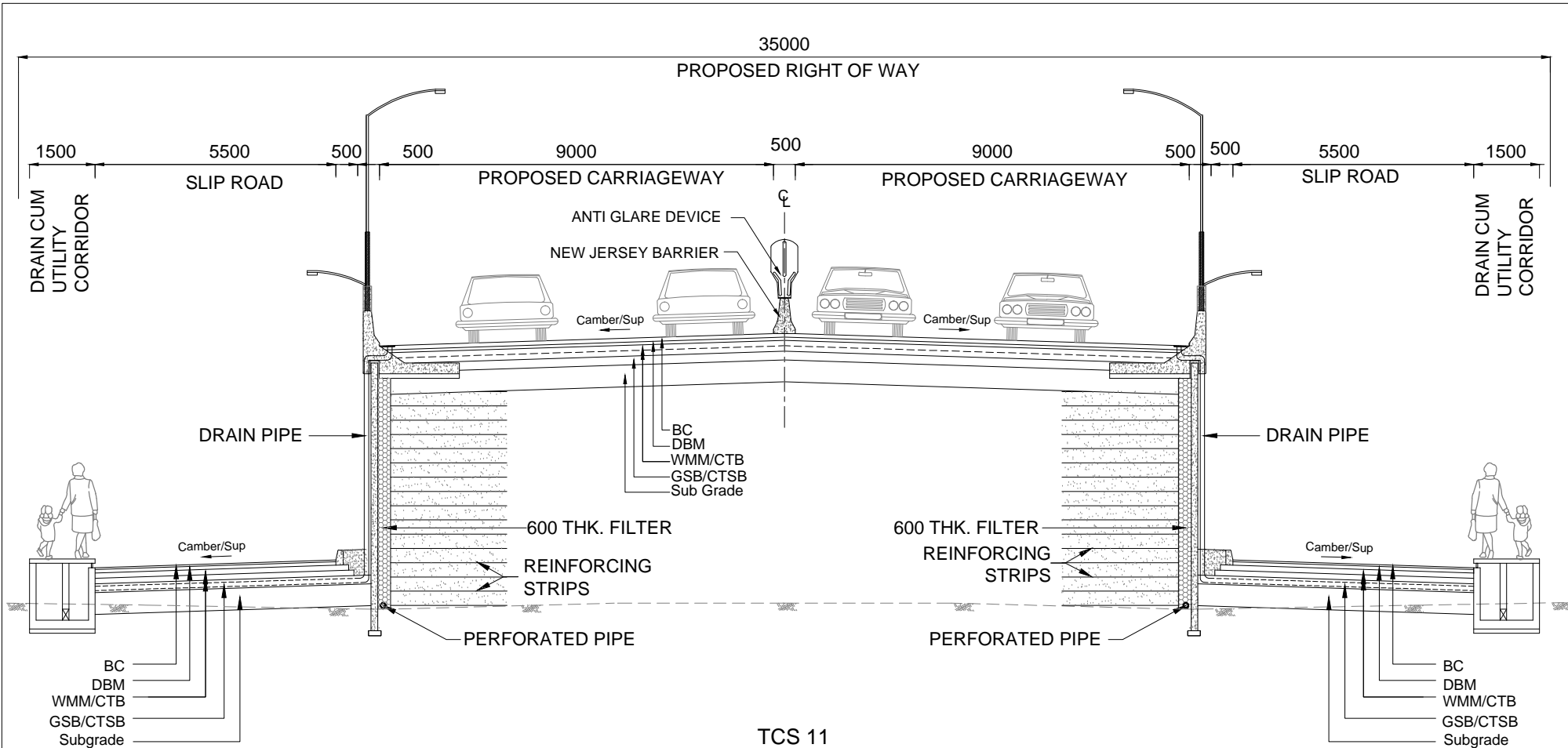

TCS 11
TYPICAL CROSS SECTION FOR 4 LANE GRADE SEPARATED APPROACH WITH BOTH SIDE SLIP ROAD

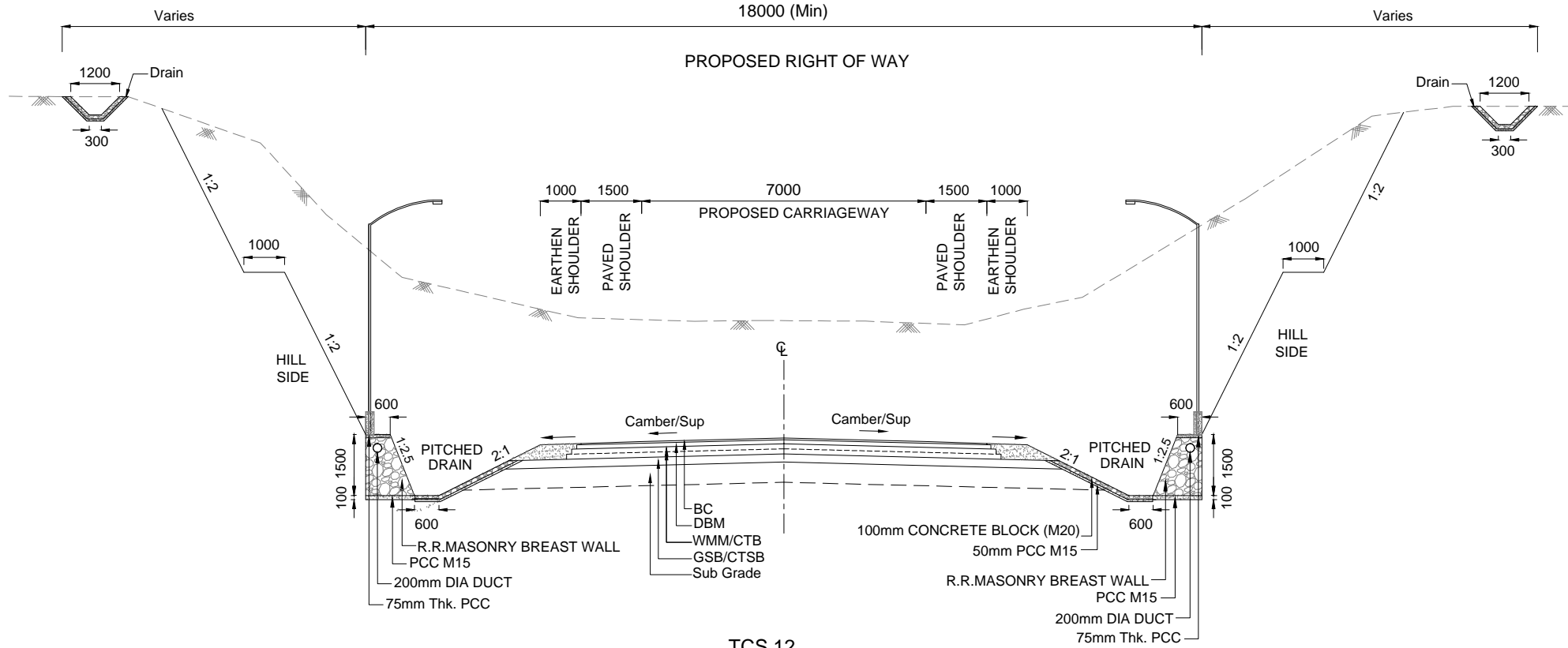

- Note :**
- (1) All Dimensions are in mm unless otherwise specified.
 - (2) For Details of New Jersey Barrier, Anti Glare Device and Kerb Refer TCS 16.

 PUBLIC WORKS DEPARTMENT GOVERNMENT OF MANIPUR	Project Title:- Consultancy Services for Feasibility Study and Preparation of Detailed Project Report for Proposed Construction of Imphal Ring Road in the state of Manipur (Imphal Ring Road)	Scale:- Not to Scale	Drawing Name:- DETAILED PROJECT REPORT TYPICAL CROSS SECTION	Intercontinental Consultants & Technocrats Pvt Ltd, A-8, Green Park, New Delhi - 110016 Ph : 4086-3000, Fax : 2685-5252	<table border="1" style="width: 100%; border-collapse: collapse;"> <tr> <td>R0</td> <td>September, 2022</td> <td>Initial Drawings</td> </tr> <tr> <td>Revisions</td> <td>Date</td> <td>Description</td> </tr> <tr> <td colspan="3" style="text-align: center;">Revisions</td> </tr> <tr> <td colspan="3" style="font-size: x-small;"> DRAWING No:- PWD/IMPHAL RING ROAD/TCS/ 21 /R0 FILE NAME:- </td> </tr> </table>	R0	September, 2022	Initial Drawings	Revisions	Date	Description	Revisions			DRAWING No:- PWD/IMPHAL RING ROAD/TCS/ 21 /R0 FILE NAME:-		
	R0	September, 2022	Initial Drawings														
	Revisions	Date	Description														
Revisions																	
DRAWING No:- PWD/IMPHAL RING ROAD/TCS/ 21 /R0 FILE NAME:-																	
<table border="1" style="width: 100%; border-collapse: collapse;"> <tr> <td style="width: 25%;"></td> <td style="width: 25%;"></td> <td style="width: 25%;"></td> <td style="width: 25%;"></td> </tr> <tr> <td style="font-size: x-small;">Prepared by</td> <td style="font-size: x-small;">Designed by</td> <td style="font-size: x-small;">Checked by</td> <td style="font-size: x-small;">Approved by</td> </tr> </table>								Prepared by	Designed by	Checked by	Approved by						
Prepared by	Designed by	Checked by	Approved by														
- 70 -																	



TCS 12
TYPICAL CROSS SECTION - 2 LANE GREEN FIELD BOX CUT - HILL

Note :
 All Dimensions are in mm unless otherwise specified.

 PUBLIC WORKS DEPARTMENT GOVERNMENT OF MANIPUR	Project Title:- Consultancy Services for Feasibility Study and Preparation of Detailed Project Report for Proposed Construction of Imphal Ring Road in the state of Manipur (Imphal Ring Road)	Scale:- Not to Scale	Drawing Name:- DETAILED PROJECT REPORT TYPICAL CROSS SECTION	 Intercontinental Consultants & Technocrats Pvt Ltd, A-8, Green Park, New Delhi - 110016 Ph : 4086-3000, Fax : 2685-5252	R0 Revisions	September, 2022 Date	Initial Drawings Description	Checked by
					Revisions			
					DRAWING No:- PWD/IMPHAL RING ROAD/TCS/ 22 /R0 FILE NAME:-			

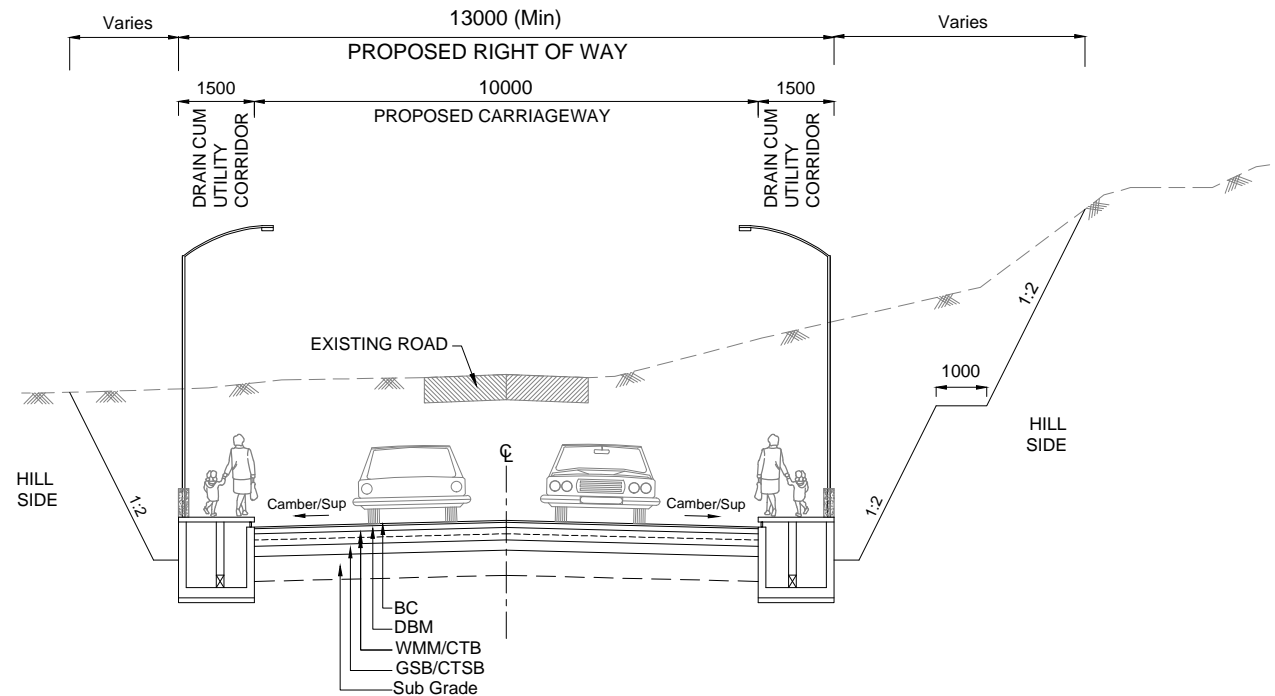

TCS 12A
 TYPICAL CROSS SECTION - 2 LANE IN EXISTING SECTION IN BOX CUT - HILL

Note :
 All Dimensions are in mm unless otherwise specified.



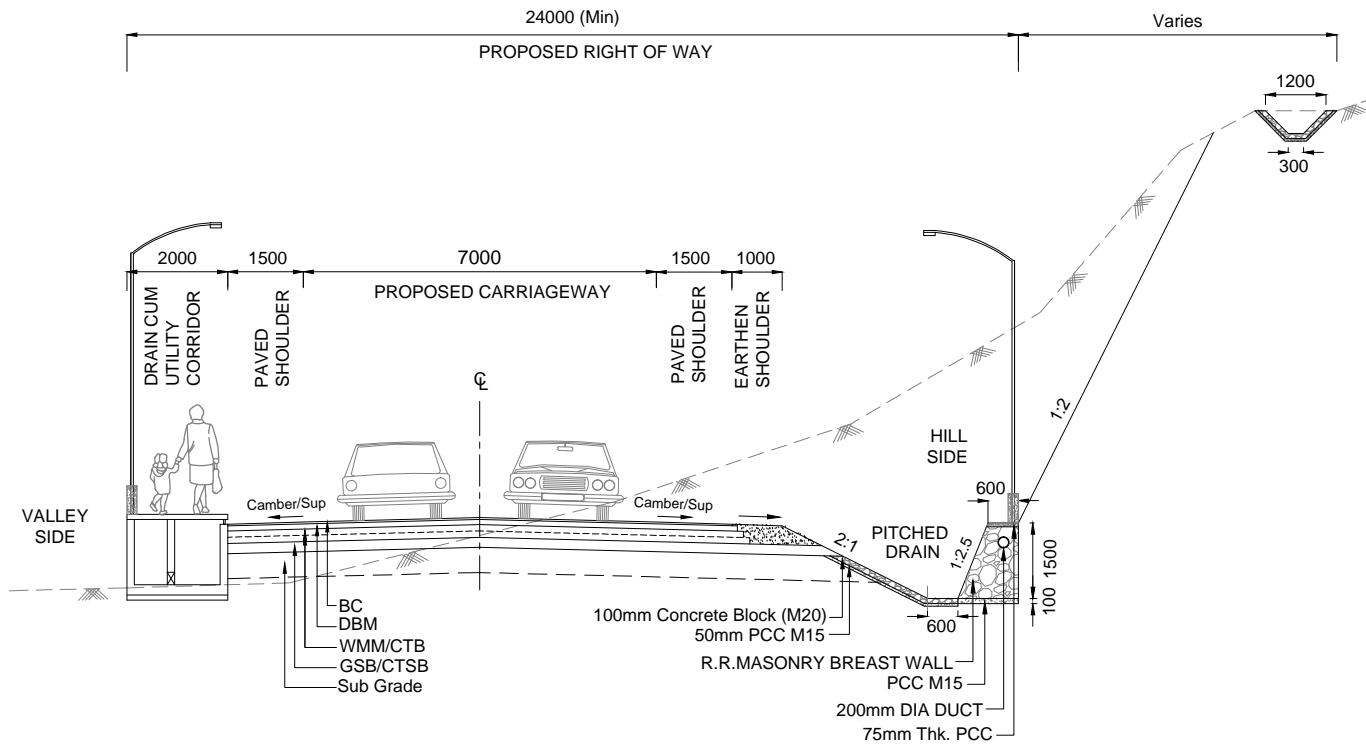

 PUBLIC WORKS DEPARTMENT GOVERNMENT OF MANIPUR	Project Title:- Consultancy Services for Feasibility Study and Preparation of Detailed Project Report for Proposed Construction of Imphal Ring Road in the state of Manipur (Imphal Ring Road)	Scale:- Not to Scale	Drawing Name:- DETAILED PROJECT REPORT TYPICAL CROSS SECTION	Intercontinental Consultants & Technocrats Pvt Ltd, A-8, Green Park, New Delhi - 110016 Ph : 4086-3000, Fax : 2685-5252	R0 Revisions	September, 2022 Date	Initial Drawings Description	Checked by
	Revisions							
	DRAWING No:- PWD/IMPHAL RING ROAD/TCS/ 23 /R0					FILE NAME:-		



TCS 13
TYPICAL CROSS SECTION - 2 LANE GREEN FIELD WITH HALF CUT - RHS

Note :

(1) All Dimensions are in mm unless otherwise specified.

 PUBLIC WORKS DEPARTMENT GOVERNMENT OF MANIPUR	Project Title:-	Scale:-	Drawing Name:-	Intercontinental Consultants & Technocrats Pvt Ltd, A-8, Green Park, New Delhi - 110016 Ph : 4086-3000, Fax : 2685-5252	R0	September, 2022	Initial Drawings	
	Consultancy Services for Feasibility Study and Preparation of Detailed Project Report for Proposed Construction of Imphal Ring Road in the state of Manipur (Imphal Ring Road)	Not to Scale	DETAILED PROJECT REPORT TYPICAL CROSS SECTION		Revisions	Date	Description	Checked by
						Revisions		
				 Hilsitt Prepared by	 B.K Swain Designed by	 Anand Prabhakar Checked by	 Dinesh Kumar Approved by	DRAWING No:- PWD/IMPHAL RING ROAD/TCS/ 24 /R0
								FILE NAME:-

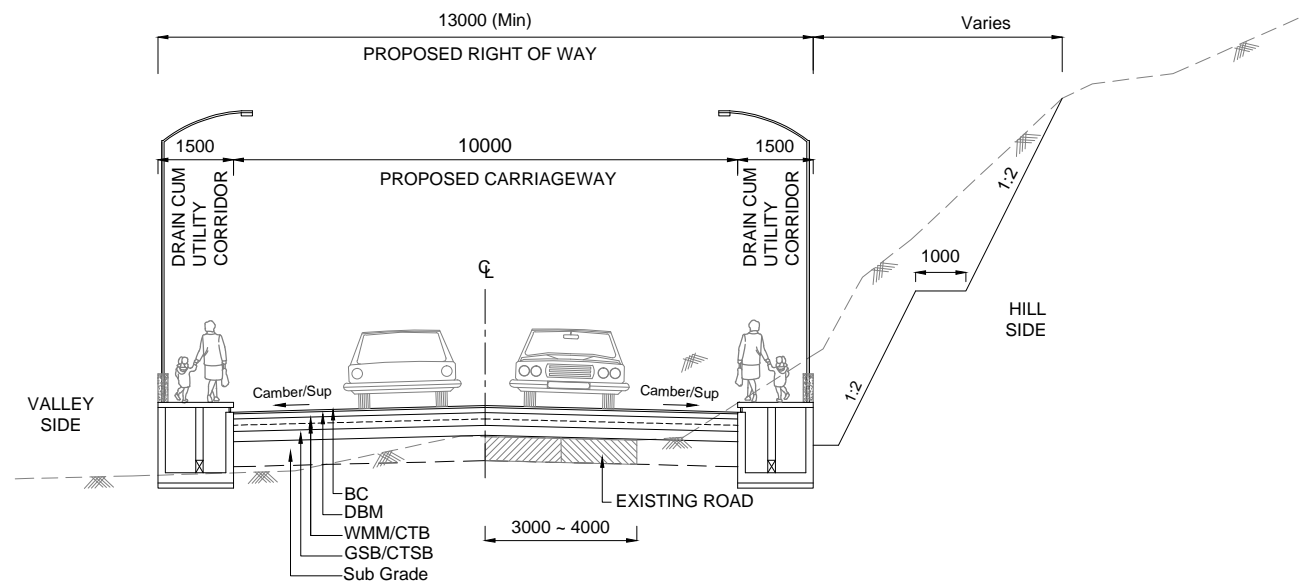

TCS 13A
TYPICAL CROSS SECTION - 2 LANE IN BUILT UP SECTION WITH HALF CUT - RHS

Note :
 (1) All Dimensions are in mm unless otherwise specified.



PUBLIC WORKS DEPARTMENT
GOVERNMENT OF MANIPUR

Project Title:-
 Consultancy Services for Feasibility Study and Preparation of Detailed Project Report for Proposed Construction of Imphal Ring Road in the state of Manipur (Imphal Ring Road)

Scale:-
 Not to Scale

Drawing Name:-
 DETAILED PROJECT REPORT
 TYPICAL CROSS SECTION



Intercontinental Consultants & Technocrats Pvt Ltd,
 A-8, Green Park, New Delhi - 110016
 Ph : 4086-3000, Fax : 2685-5252





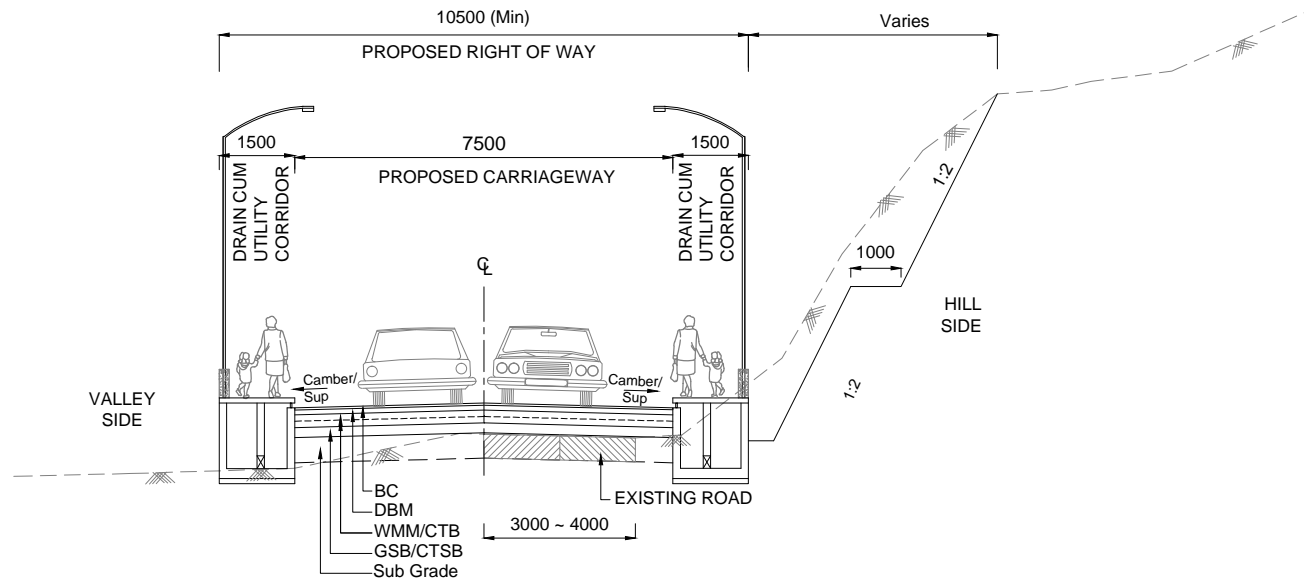

Prepared by Hillsitt	Designed by B.K Swain	Checked by Ajayesh Prabhakar	Approved by Dipankar Kumar
-------------------------	--------------------------	---------------------------------	-------------------------------

R0	September, 2022	Initial Drawings	
Revisions	Date	Description	Checked by
Revisions			
DRAWING No:- PWD/IMPHAL RING ROAD/TCS/ 25 /R0			FILE NAME:-



TCS 13B
TYPICAL CROSS SECTION - 2 LANE IN RESTRICTED AREA WITH HALF CUT - RHS

Note :
 (1) All Dimensions are in mm unless otherwise specified.

 PUBLIC WORKS DEPARTMENT GOVERNMENT OF MANIPUR	Project Title:- Consultancy Services for Feasibility Study and Preparation of Detailed Project Report for Proposed Construction of Imphal Ring Road in the state of Manipur (Imphal Ring Road)	Scale:- Not to Scale	Drawing Name:- DETAILED PROJECT REPORT TYPICAL CROSS SECTION	 Intercontinental Consultants & Technocrats Pvt Ltd, A-8, Green Park, New Delhi - 110016 Ph : 4086-3000, Fax : 2685-5252	R0	September, 2022	Initial Drawings	
					Revisions	Date	Description	Checked by
					Revisions			
Prepared by:  Hilsitt Designed by:  B.K Swain Checked by:  Anand Prabhakar Approved by:  Dinesh Kumar					DRAWING No:- PWD/IMPHAL RING ROAD/TCS/ 26 /R0 FILE NAME:-			

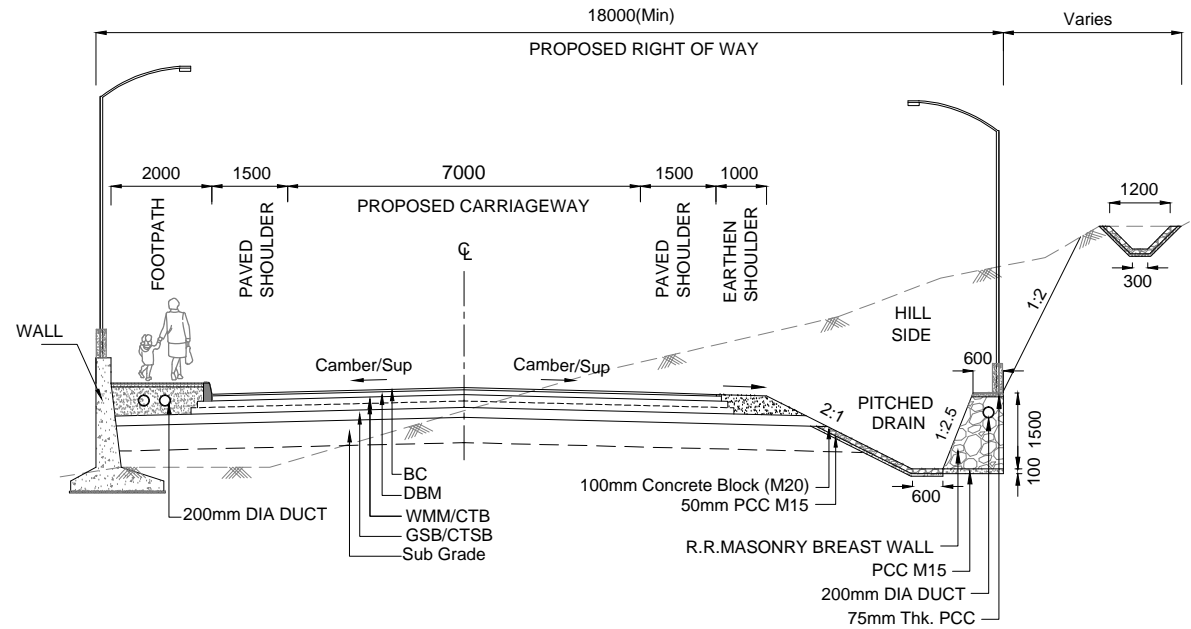

TCS 14
TYPICAL CROSS SECTION - 2 LANE WITH HALF CUT - RHS & HIGH EMBANKMENT ON LHS

Note :
 All Dimensions are in mm unless otherwise specified.

 PUBLIC WORKS DEPARTMENT GOVERNMENT OF MANIPUR	Project Title:- Consultancy Services for Feasibility Study and Preparation of Detailed Project Report for Proposed Construction of Imphal Ring Road in the state of Manipur (Imphal Ring Road)	Scale:- Not to Scale	Drawing Name:- DETAILED PROJECT REPORT TYPICAL CROSS SECTION	Intercontinental Consultants & Technocrats Pvt Ltd, A-8, Green Park, New Delhi - 110016 Ph : 4086-3000, Fax : 2685-5252	R0 Revisions	September, 2022 Date	Initial Drawings Description	Checked by
					Revisions			
					Prepared by Hilsitt	Designed by B.K Swain	Checked by Anand Prabhakar	Approved by Dinesh Kumar

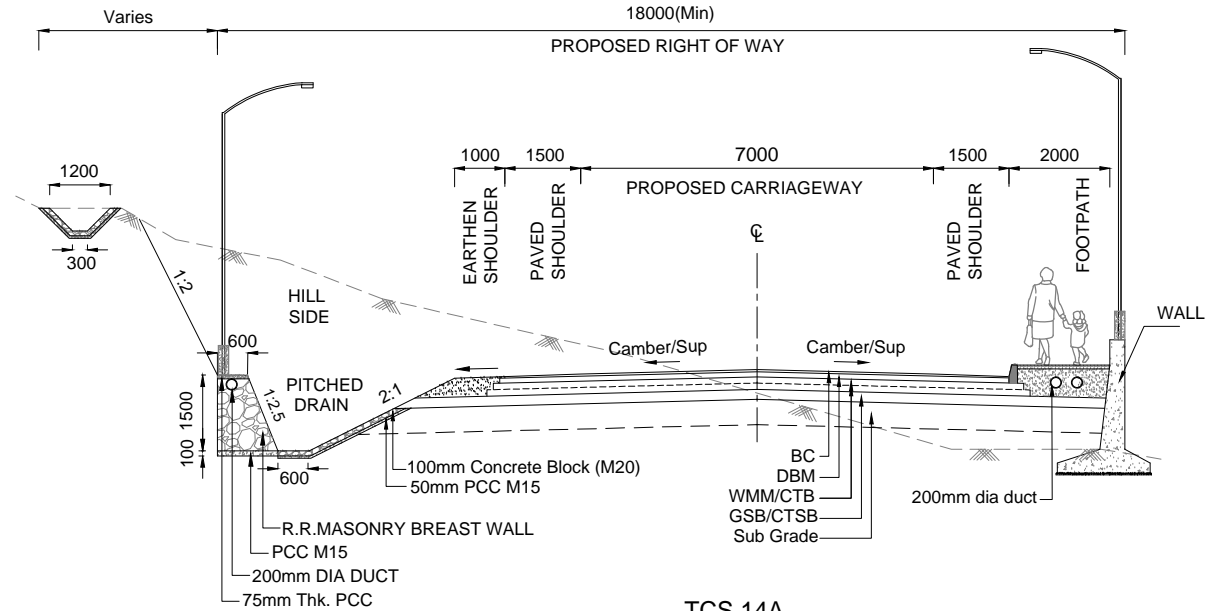

TCS 14A
TYPICAL CROSS SECTION - 2 LANE ON EXISTING WITH
HALF CUT - LHS & HIGH EMBANKMENT ON RHS

Note :
 All Dimensions are in mm unless otherwise specified.



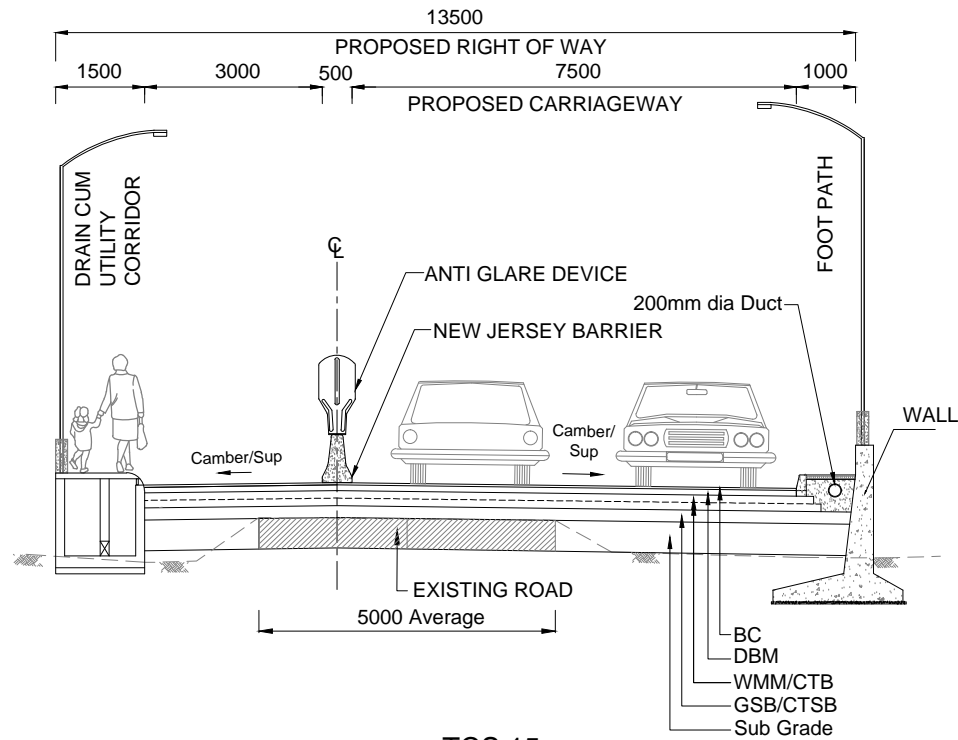



 PUBLIC WORKS DEPARTMENT GOVERNMENT OF MANIPUR	Project Title:- Consultancy Services for Feasibility Study and Preparation of Detailed Project Report for Proposed Construction of Imphal Ring Road in the state of Manipur (Imphal Ring Road)	Scale:- Not to Scale	Drawing Name:- DETAILED PROJECT REPORT TYPICAL CROSS SECTION	Intercontinental Consultants & Technocrats Pvt Ltd, A-8, Green Park, New Delhi - 110016 Ph : 4086-3000, Fax : 2685-5252	R0 Revisions	September, 2022 Date	Initial Drawings Description	Checked by	
					Revisions				
					Prepared by Hilsitt	Designed by B.K Swain	Checked by Anand Prabhakar	Approved by Dinesh Kumar	DRAWING No:- PWD/IMPHAL RING ROAD/TCS/ 28/R0 FILE NAME:-



TCS 15
TYPICAL CROSS SECTION FOR 2 LANE WITH CYCLE TRACK ON CANAL BOND

Note :

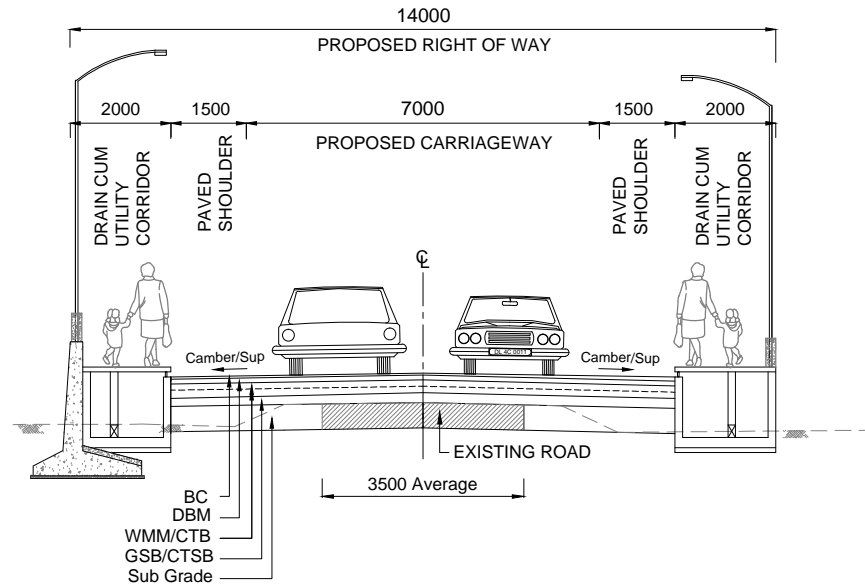

- (1) All Dimensions are in mm unless otherwise specified.
- (2) For details of New Jersey Barrier and Anti Glare Device refer TCS 16.

 PUBLIC WORKS DEPARTMENT GOVERNMENT OF MANIPUR	Project Title:- Consultancy Services for Feasibility Study and Preparation of Detailed Project Report for Proposed Construction of Imphal Ring Road in the state of Manipur (Imphal Ring Road)	Scale:- Not to Scale	Drawing Name:- DETAILED PROJECT REPORT TYPICAL CROSS SECTION	 Intercontinental Consultants & Technocrats Pvt Ltd, A-8, Green Park, New Delhi - 110016 Ph : 4086-3000, Fax : 2685-5252	R0	September, 2022	Initial Drawings	
					Revisions	Date	Description	Checked by
					Revisions			
Prepared by:  Hilsitt Designed by:  B.K Swain Checked by:  Aswini Prabhakar Approved by:  Dinesh Kumar					DRAWING No:- PWD/IMPHAL RING ROAD/TCS/ 29/R0 FILE NAME:-			



TCS 15A
TYPICAL CROSS SECTION FOR 2 LANE ON EXISTING WITH RETAINING WALL - LHS

Note :
 (1) All Dimensions are in mm unless otherwise specified.



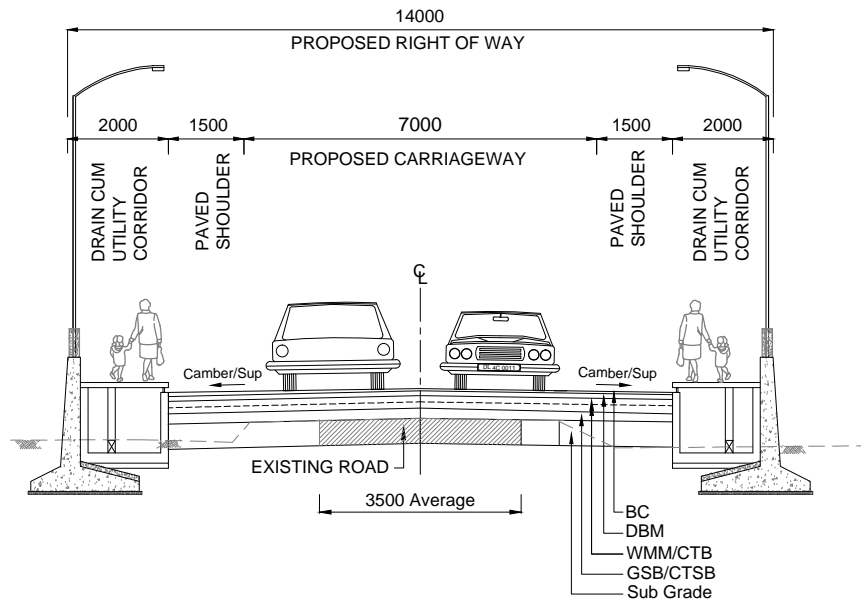



 PUBLIC WORKS DEPARTMENT GOVERNMENT OF MANIPUR	Project Title:- Consultancy Services for Feasibility Study and Preparation of Detailed Project Report for Proposed Construction of Imphal Ring Road in the state of Manipur (Imphal Ring Road)	Scale:- Not to Scale	Drawing Name:- DETAILED PROJECT REPORT TYPICAL CROSS SECTION	 Intercontinental Consultants & Technocrats Pvt Ltd, A-8, Green Park, New Delhi - 110016 Ph : 4086-3000, Fax : 2685-5252	R0	September, 2022	Initial Drawings	
					Revisions	Date	Description	Checked by
					Revisions			
DRAWING No:- PWD/IMPHAL RING ROAD/TCS/ 30 /R0					FILE NAME:-			



TCS 15B
TYPICAL CROSS SECTION ON EXISTING WITH RETAINING WALL BOTH SIDE

Note :

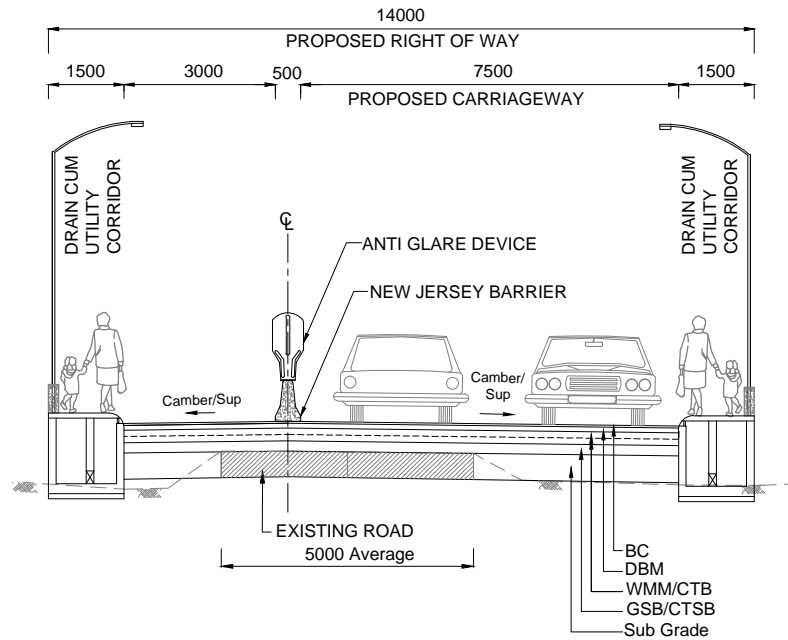

- (1) All Dimensions are in mm unless otherwise specified.

 PUBLIC WORKS DEPARTMENT GOVERNMENT OF MANIPUR	Project Title:- Consultancy Services for Feasibility Study and Preparation of Detailed Project Report for Proposed Construction of Imphal Ring Road in the state of Manipur (Imphal Ring Road)	Scale:- Not to Scale	Drawing Name:- DETAILED PROJECT REPORT TYPICAL CROSS SECTION	 Intercontinental Consultants & Technocrats Pvt Ltd, A-8, Green Park, New Delhi - 110016 Ph : 4086-3000, Fax : 2685-5252	R0	September, 2022	Initial Drawings	
					Revisions	Date	Description	Checked by
					Revisions			
Prepared by:  Hilsitt Designed by:  B.K Swain Checked by:  Ananta Prabhakar Approved by:  Dinesh Kumar					DRAWING No:- PWD/IMPHAL RING ROAD/TCS/ 31/R0 FILE NAME:-			



TCS 15C
TYPICAL CROSS SECTION FOR 2 LANE WITH CYCLE TRACK ON BUILT UP SECTION





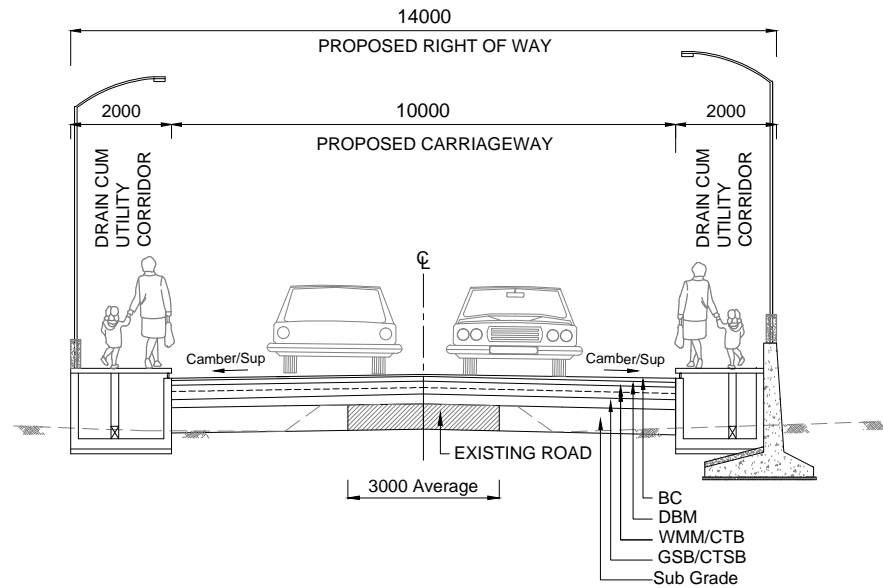

- Note :
- (1) All Dimensions are in mm unless otherwise specified.
 - (2) For details of New Jersey Barrier and Anti Glare Device refer TCS 16.

 PUBLIC WORKS DEPARTMENT GOVERNMENT OF MANIPUR	Project Title:- Consultancy Services for Feasibility Study and Preparation of Detailed Project Report for Proposed Construction of Imphal Ring Road in the state of Manipur (Imphal Ring Road)	Scale:- Not to Scale	Drawing Name:- DETAILED PROJECT REPORT TYPICAL CROSS SECTION	 Intercontinental Consultants & Technocrats Pvt Ltd, A-8, Green Park, New Delhi - 110016 Ph : 4086-3000, Fax : 2685-5252	R0 Revisions	September, 2022 Date	Initial Drawings Description	Checked by
					Revisions			
					DRAWING No:- PWD/IMPHAL RING ROAD/TCS/ 32 /R0 FILE NAME:-			



TCS 15D
TYPICAL CROSS SECTION FOR 2 LANE ON EXISTING SECTION WITH RETAINING WALL - RHS





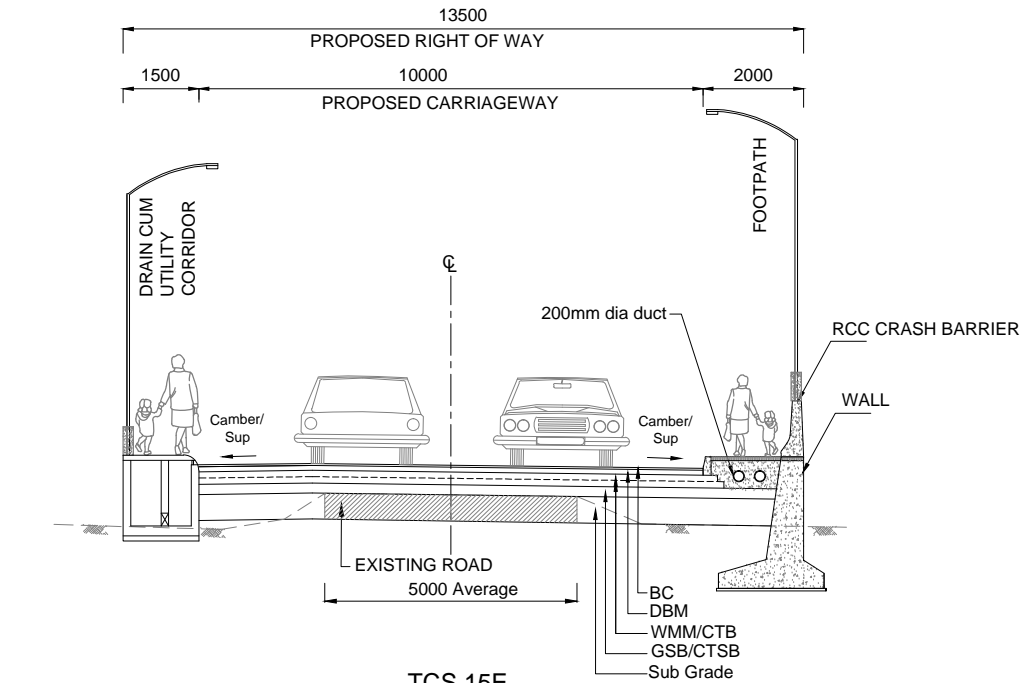

Note :
 (1) All Dimensions are in mm unless otherwise specified.

 PUBLIC WORKS DEPARTMENT GOVERNMENT OF MANIPUR	Project Title:- Consultancy Services for Feasibility Study and Preparation of Detailed Project Report for Proposed Construction of Imphal Ring Road in the state of Manipur (Imphal Ring Road)	Scale:- Not to Scale	Drawing Name:- DETAILED PROJECT REPORT TYPICAL CROSS SECTION	 Intercontinental Consultants & Technocrats Pvt Ltd, A-8, Green Park, New Delhi - 110016 Ph : 4086-3000, Fax : 2685-5252	R0	September, 2022	Initial Drawings	
					Revisions	Date	Description	Checked by
					Revisions			
Prepared by:  Hilsit Designed by:  B.K Swain Checked by:  Ananta Prabhakar Approved by:  Dinesh Kumar					DRAWING No:- PWD/IMPHAL RING ROAD/TCS/ 33/R0 FILE NAME:-			



TCS 15E
TYPICAL CROSS SECTION FOR 2 LANE ON
EXISTING SECTION (WITH EXISTING NALA) WITH RETAINING WALL - RHS

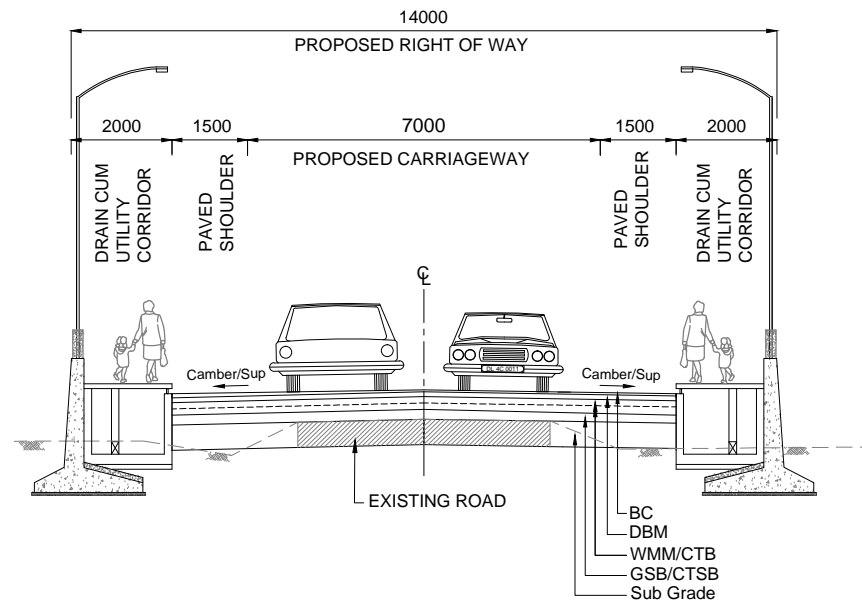

Note :
 (1) All Dimensions are in mm unless otherwise specified.

 PUBLIC WORKS DEPARTMENT GOVERNMENT OF MANIPUR	Project Title:- Consultancy Services for Feasibility Study and Preparation of Detailed Project Report for Proposed Construction of Imphal Ring Road in the state of Manipur (Imphal Ring Road)	Scale:- Not to Scale	Drawing Name:- DETAILED PROJECT REPORT TYPICAL CROSS SECTION	 Intercontinental Consultants & Technocrats Pvt Ltd, A-8, Green Park, New Delhi - 110016 Ph : 4086-3000, Fax : 2685-5252	R0	September, 2022	Initial Drawings	
					Revisions	Date	Description	Checked by
					Revisions			
Prepared by:  Hilsitt Designed by:  B.K Swain Checked by:  Asoem Prabhakar Approved by:  Dinesh Kumar					DRAWING No:- PWD/IMPHAL RING ROAD/TCS/ 34 /R0 FILE NAME:-			



TCS 15F
TYPICAL CROSS SECTION FOR 2 LANE ON
EXISTING SECTION WITH RETAINING WALL - BOTH

Note :
 (1) All Dimensions are in mm unless otherwise specified.

 PUBLIC WORKS DEPARTMENT GOVERNMENT OF MANIPUR	Project Title:-	Scale:-	Drawing Name:-	Intercontinental Consultants & Technocrats Pvt Ltd, A-8, Green Park, New Delhi - 110016 Ph : 4086-3000, Fax : 2685-5252 	R0	September, 2022	Initial Drawings	
	Consultancy Services for Feasibility Study and Preparation of Detailed Project Report for Proposed Construction of Imphal Ring Road in the state of Manipur (Imphal Ring Road)	Not to Scale	DETAILED PROJECT REPORT TYPICAL CROSS SECTION		Revisions	Date	Description	Checked by
					Revisions			
DRAWING No:- PWD/IMPHAL RING ROAD/TCS/ 35/R0				FILE NAME:-				

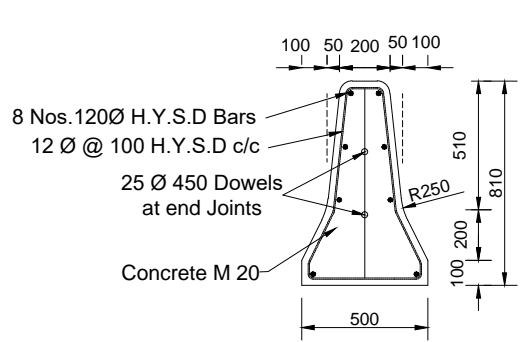

NEW JERSEY BARRIER

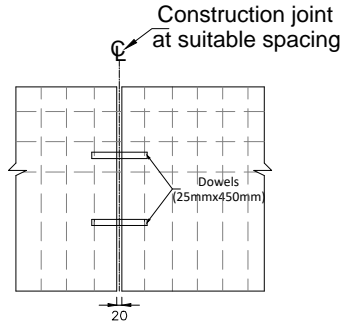

JOINT DETAIL OF NEW JERSEY BARRIER

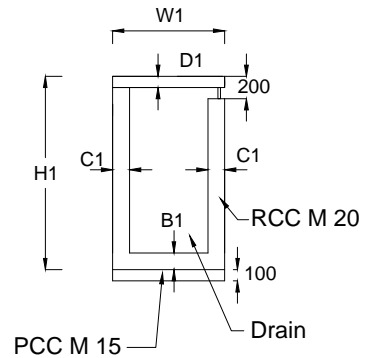

DRAIN - A

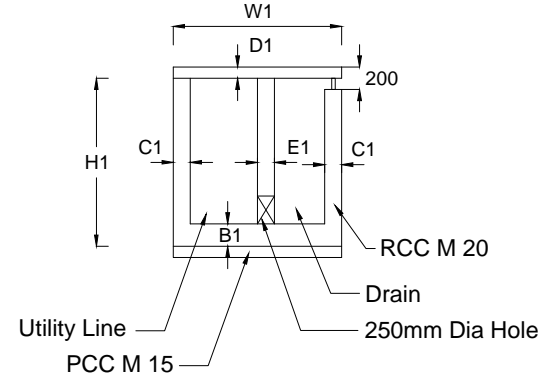

DRAIN CUM UTILITY CORRIDOR - B

DETAILS OF DRAIN - 'A'				
Height (mm)	Width (mm)	Base Thickness (mm)	Side Wall Thickness (mm)	Slab Thickness (mm)
H1	W1	B1	C1	D1
1000	1000	100	100	100
1250	1000	125	125	100
1500	1000	125	125	100

DETAILS OF DRAIN CUM UTILITY CORRIDOR 'B'					
Height (mm)	Width (mm)	Base Thickness (mm)	Side Wall Thickness (mm)	Slab Thickness (mm)	Center Wall Thickness (mm)
H1	W1	B1	C1	D1	E1
1000	1500	100	100	100	100
1250	1500	125	125	100	100
1500	1500	125	125	100	100
1750	1500	125	125	100	100
2000	1500	150	150	100	100
2250	1500	150	150	100	100
2500	1500	175	175	100	100

DETAILS OF DRAIN CUM UTILITY CORRIDOR 'C'					
Height (mm)	Width (mm)	Base Thickness (mm)	Side Wall Thickness (mm)	Slab Thickness (mm)	Center Wall Thickness (mm)
H1	W1	B1	C1	D1	E1
1000	2000	100	100	100	100
1250	2000	125	125	100	100
1500	2000	125	125	100	100
1750	2000	125	125	100	100
2000	2000	150	150	100	100
2250	2000	150	150	100	100
2500	2000	175	175	100	100

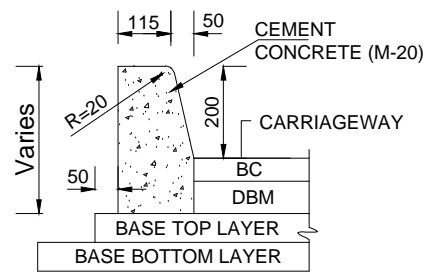

SECTION OF BARRIER TYPE KERB

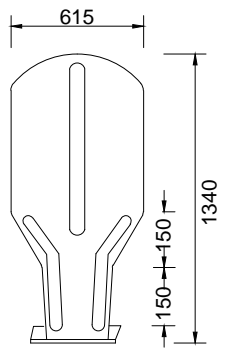

TYPICAL DETAILS OF ANTI GLARE DEVICE

TYPICAL CROSS SECTION 16

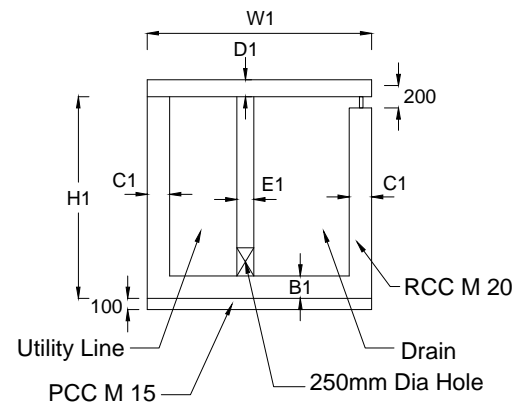

DRAIN CUM UTILITY CORRIDOR - C

- Note :
1. All Dimensions are in mm unless otherwise specified.
 2. The slab thickness of drain at cross road locations shall be designed for vehicular load